

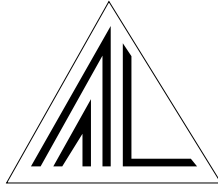

Australian Journal
of **Liturgy**

VOLUME 13 NUMBER 3 2013



AUSTRALIAN ACADEMY OF LITURGY

Australian Journal of **Liturgy**

VOLUME 13 **NUMBER 3** 2013

Editor Robert Gribben

Editorial Panel Stephen Burns (Book Review Editor)
Russell Hardiman
Clare V. Johnson
David Pitman
Charles Sherlock

AJL is the journal of the Australian Academy of Liturgy and exists to further the study of liturgy at a scholarly level, and to comment on and provide information concerning liturgical matters with special reference to Australia. AJL is published twice a year.

ISSN 1030-617X

Cover image: This glimpse of a liturgy in the crypt of St Peter's basilica in Rome raises some of the questions asked at our Hobart Conference, e.g. by Fr Peter Williams: 'Does the disposition of the reader and their gender make a difference to the way that the Word is heard and received? Do we hear parts of the Scripture differently depending on context? Should the passages of Scripture proclaimed challenge and disturb? Does the Scripture propel us into action? As the Word of God, are we more attentive to its proclamation than other parts of the liturgy?' Photo courtesy of Jeremy Yuen.

Australian Journal of Liturgy

Volume 13 Number 2 (2012)

Council 2012

President:	Angela McCarthy, BA, BEd, MEd (RE), PhD
Past President:	David Pitman, BA, BD, DipEd, PhD
Secretary:	John McCarthy BA, Grad Dip.
Treasurer:	John Dunn, LTh, GradDipCommunityCounselling
Editor of AJL:	Robert Gribben BA, MA, TheolM, DD (h.c.)
Website Editor:	Paul Mason, BE (Elec), MA (Theology), MA (Liturgy)

Chapter Convenors:

<i>Queensland</i>	Inari Thiel, MSc, MA, GradDipTheol
<i>New South Wales</i>	Monica Barlow rsj, BA, DipEd, GradDipRE, MA (Theol.)
<i>Victoria</i>	Anthony Doran, BA (Hons), BTheol, GradDipEd (Sec), MTS D'Arcy Wood, MA, BD (Hons), PhD, ARSCM (co-convenors)
<i>Tasmania</i>	Alison Whish BA, BSocAdmin, DipMin, MTS
<i>South Australia</i>	Ilsa Neicinieks rsm, MEd, MA (Lit Studs)
<i>Western Australia</i>	Vivien Larkin B.Theol

Membership of the Academy

Admission to the Academy is open to those who have recognised qualifications in liturgical studies and related disciplines. The Academy also admits those who have demonstrated in other ways their professional competence in these fields or who evidence a developing contribution in the area of worship.

The Academy hopes that the work of members will serve to animate the liturgical spirit of the traditions and congregations to which they belong.

Applications are invited and should be made on an application form available from:

The Secretary

Australian Academy of Liturgy

Maritime Avenue

Kardinya, WA, 6163.

Email: angela.mccarthy@nd.edu.au

Contents

Editorial 98

Conference keynote addresses:

*Transcending Text: Liturgy as Medium
of Evangelisation 50 years after Vatican II
Clare V. Johnson 100

*Liturgy and Sound
Peter Williams 118

Liturgical Renewal: Presence
Colleen O'Reilly 129

*The Liturgical Consummation of Space
Stephen Hackett 140

Article

*The Ecumenical Liturgical Centre 1962-1989
Robert Gribben 155

Academy Reports

From the President 166

From the Chapters 168

Book reviews – a note

Stephen Burns 170

AJL addresses, subscription information

Articles with an asterisk are peer-reviewed.*

Editorial



I have two new service booklets on my desk. The first is a small, compact handbook of some 120 pages entitled *Inizio del Ministero Petrino del Vescovo di Roma, 19 Marzo 2013*, the feast day of St Joseph. The right-hand pages contain the liturgical text, including chant, in Latin and Italian as these were used in the public rite, Greek for the Gospel and, in appropriate script, Russian, French, Arabic, Swahili, Chinese and Italian for the prayers of the faithful. On the left hand page, everything was translated into Italian and English. The rubrics are – pink. It was, fundamentally, a Mass over which the Bishop of Rome presided in the presence of a couple of hundred thousand of his people, on an exquisitely sunny day in the open air in front of St Peter's Basilica. Anything else – the Imposition of the Pallium and the Bestowal of the Fisherman's Ring – was enacted prior to *Santa Messa*. Apart from the numbers and the setting, it felt (to this non-Roman guest) like a bishop celebrating with his people.

The other is larger (quarto) and shorter (43 pages), entitled *The Inauguration of the Ministry of the One Hundred and Fifth Archbishop of Canterbury, 21 March 2013 At Three O'Clock* (just before tea), and lists the two feasts of the day, of Benedict and Thomas Cranmer. The service took place inside the Cathedral and Metropolitan Church of Christ, Canterbury. It was a Service of the Word, much of it concerned with the legalities of the Established Church of England. There are about 13 pages listing the persons who form the divers Processions. As a participant, I must say the day was dominated by standing about in the crypt robing and being put in order; the result was, however, a miraculous precision in everyone being in the right place and the right time, looking splendid (or in my case, sober). The music represented a wide variety of eras and cultures, but I freely confess to a touch to ecstasy in joining with choir and organ and two thousand Anglicans in singing Charles Wesley's *And Can It Be* (to *Sagina*). I was, after all, representing (however ironically for an Australian) the World Methodist Council.

An Editorial is no place for analysis, but I was reminded at both liturgies of the old story of a Pope preaching in that Basilica on the subject of humility – only the basilica shouted him down. Pope Francis may well challenge that, but so also will Archbishop Justin Welby. Both were palpably present as people of prayer in rather grand contexts. Neither made any gesture based on the behaviour of Presidents or film stars. Both occasions prompted me to think of the themes of our Hobart Conference last January: *Liturgical Renewal: Sound, Space, Presence*.



Photo courtesy of Julie Moran

Alison Whish, Brian Nicholls (Tas.) and Anthony Kain (S.A.) prepare to welcome delegates to the Hobart Conference.

This issue of AJL contains the keynote addresses of the Conference, plus Dr Clare V. Johnson's public lecture which describes the liturgical influence of the late Catholic Archbishop of Hobart, Dr Guilford Young, and measures contemporary issues against his pleas.

Readers will have been looking forward to reading Part 2 of Sr Dr Margaret Smith's first essay in our last issue on 'Sacrosanctum Concilium: The Australian Way', but sickness has prevented her completing this – but it is promised for our October issue. We wish her a quick recovery.

We also congratulate a recent Academy member, Philip Nicholls, on his appointment as Director of Music at St Paul's Anglican Cathedral in Melbourne. He succeeds Dr June Nixon AM who held that position for forty years. Philip was previously Director of Music at Christ Church, South Yarra, a parish church with a choir school well known for its excellence. In addition he served on the music staff of Trinity College, University of Melbourne, and is General Editor of the Australian Hymn Book Company. And behind all that is a lifetime of music-making as choirboy, choral scholar, conductor – and of practice and study both in Australia and overseas. This is significant appointment within the national network of liturgists and musicians and we wish him well.

Robert Gribben

Remember to check our website at www.liturgy.org.au.

Transcending Text: Liturgy as Medium of Evangelisation 50 years after Vatican II

Clare V. Johnson



Dr. Clare V. Johnson is Senior Lecturer in Liturgical Studies and Sacramental Theology at Australian Catholic University (Strathfield, NSW). Her research is published in *Studia Liturgica*, *Worship*, *Liturgy*, *Australian Journal of Liturgy*, *Pastoral Liturgy*, and other journals. She is editor of *Ars Liturgiae: Worship, Aesthetics and Praxis* (Chicago: LTP, 2003) and contributing co-editor of *Vatican II: Reception and Implementation in the Australian Church* (Mulgrave: Garrett, 2012). She serves as assistant editor of *Studia Liturgica* and is a member of the National Liturgical Council advising the Australian Bishops' Commission on the Liturgy. The article is her public address during the Hobart Conference of the Academy.

Introduction

In 1939 on the eve of the outbreak of World War II, a bright 24-year-old newly-ordained Australian priest left Rome to travel back to his native Queensland after the completion of his doctoral studies. On his journey home, he stopped off in the USA to visit an isolated Benedictine monastery where he reacquainted himself with a monk who changed the course of his life. The young priest was none other than Guilford Young and the monk was the eminent Benedictine liturgist and leading light of the American Liturgical Movement, Fr. Godfrey Diekmann,¹ whom Young had met during his time in Rome. Young's brief visit to St. John's Abbey at Collegeville, Minnesota, reignited his interest in the work of the Liturgical Movement which eventually led to friendships with other eminent liturgists of the day such as Fred McManus, Clifford Howell, Percy Jones and others 'of a small band who...were known as the "liturbugs";² and who worked assiduously to promote the Liturgical Movement in their respective English-speaking contexts.

In his heyday, Archbishop Sir Guilford Young was a force to be reckoned with: a tireless and brilliant campaigner for the reform of the liturgy, the founding Vice President of the International Commission on English in the Liturgy, one of the 42

¹ Edmund Campion, *Australian Catholics* (Ringwood VIC: Penguin, 1988), 210.

² 'Archbishop Young Probes Decree on Liturgy,' *The Standard* (December 27, 1963): 8.



bishops appointed by Pope Paul VI to the Consilium charged with implementing Vatican II's Constitution on the Sacred Liturgy, a member of the Sacred Congregation for Divine Worship (from 1984) and a Knight of the British Empire for service to the church of Tasmania (1978). Dr Young was the youngest ever Australian bishop, consecrated at the age of 31. He became Archbishop of Hobart at only 38 and held that post for the next 34 years, from September 20, 1955 until his death on March 16, 1988. This long life of leadership and service left an extraordinary legacy, particularly in terms of the liturgy. In February 1988, Fr. Godfrey Diekmann wrote a final letter to his good friend Guilford Young in which he says:

You...have been a Lumen [light], a true and bright reflection of the Lumen who is Christ, Lumen for its enlightenment of countless Fideles [members of the faithful], through your work at the Council and in the Preparatory Commission, and Lumen that also gives warmth to your own priests and people of Hobart... One of my boasts through the year has been that I played a part in your 'conversion' to the liturgy.³

The importance of the liturgical contribution Archbishop Young made both to the Australian and world scene in the years immediately following Vatican II is a topic which has been largely overlooked in Australian Catholic history. This paper will begin to redress this oversight and draw forth some of the still-pertinent liturgical insights of one of Australia's true liturgical pioneers.

Part I: Contextualising Vatican II's liturgical reform in Australia

For a number of years now in the English-speaking Roman Catholic tradition, liturgists have focused a lot of time and attention on coming to terms with the new translation of the Roman Missal. Sometimes we can forget, as we drill down into the textual analysis, pastoral challenges and ecclesial ramifications of implementing the 2010 translation of the Roman Missal that we are experiencing simply the most recent in a long history of liturgical changes undertaken by the church. In 1965, Archbishop Guilford Young wrote:

³ Letter of Fr. Godfrey Diekmann, OSB to Archbishop Guilford Young, quoted in Monsignor Philip R. Green's homily at the Mass of Christian Burial for Archbishop Young, reprinted as: 'An Age of Greatness has Passed,' *The New Standard* (April 1988): 2.

We know that the Church is not perfect and that it must always be subject to reform and change.... it is good that we have been able to see changes taking place frequently in the Mass, which as the centre of the Liturgy is the heart of Catholic life.... So the annoying alterations in the liturgy have helped build into our consciousness of the Faith the great theological principle: '*Ecclesia semper reformanda*' – 'The Church is always in need of reform.' For me as a priest the new liturgy is still difficult... Difficult as the new liturgy may have been for the congregation, it has placed far heavier burdens on the priests.⁴

Young's 1965 summation of the theological principle of ecclesial change and the practical difficulties it can engender for priests and people might well have been written in response to today's circumstances as we continue to adjust to the new translation of the Mass.

In the late 1950s and early 1960s, Archbishop Guilford Young worked to advance the aim of the Liturgical Movement, namely, 'to restore as fully as possible the expressiveness and sanctifying power of the liturgy and to bring the faithful back to full participation and understanding.'⁵ Young was in good company in his efforts to make this aim a reality. The Archbishop of Milan, Giovanni Cardinal Montini wrote in April 1959⁶ that the liturgy 'is like the central artery to which other streams of private and popular prayer lead and from which others flow for the personal spiritual life.' Montini emphasised the 'stupendous formative capacity' of the liturgy for instructing children and adults, calling it 'dogma in the form of prayer.'⁷ He stated that 'the liturgy is not an action of the priests alone, but also of the faithful, in the forms of participation proper to them,' so that those 'who are lead to this participation will be educated gradually to understand the liturgy and make it their own.'⁸

Montini's 1959 call to encourage lay participation in the liturgy was echoed across the world and was put into practice in the 'liturgical workshop of Australia,'⁹ the Archdiocese of Hobart. By 1960, Archbishop Guilford Young had ensured that 'every Mass in the archdiocese featured the active participation of the laity,'¹⁰ which included all Masses being prayed in dialogue form; laymen reading the Epistle and Gospel; suitable hymns and psalms being sung; and offertory processions 'in which (usually) a man and a woman from the congregation bring the bread and wine to the altar.'¹¹ Historian Edmund Campion explains that 'More than by words from the pulpit,

⁴ Archbishop Guilford Young, 'English is merely the first step,' *The Standard* (September 17, 1965): 7.

⁵ Annibale Bugnini, *The Reform of the Liturgy 1948-1979*, trans. Matthew J. O'Connell (Collegeville: The Liturgical Press, 1990), 6.

⁶ Cardinal Montini, 'The Liturgy is Vital to All Catholics Today,' *The Catholic Leader* (April 2, 1959): 8-9.

⁷ *Ibid.*

⁸ *Ibid.*

⁹ 'Hobart is leading the way,' *The Standard* (February 19, 1965): 3.

¹⁰ Campion, 210.

¹¹ 'Archbishop Young Probes Decree on Liturgy,' *The Standard* (December, 27, 1963): 8.

Tasmanians discovered what it was all about by actually doing it. Each Sunday they learnt a new part of the Mass, even though it was in Latin. Mass hymns were set for the whole diocese, thus ensuring homogeneity.¹²

The extent of Archbishop Young's preparation of his people for the reform of the liturgy meant that when Vatican II's changes to the liturgy began to filter through in 1964, he was able to say to his people:

Fortunately, many elements will not be novel and disturbing to you because you have kept pace during recent years with the wishes and directives of the Holy See for the full, conscious and active participation of the people in the Mass.

You are already aware of the distribution of roles in the community's act of worship. You have become accustomed to doing your part and to looking upon your priests as the president of your assembly leading you in the active worship of God. You are completely familiar with the postures – the standing, kneeling, sitting – which the bishops have now laid down for Australia: they are those that you have been following for the past four years.¹³

At the same time that the people of Tasmania began moving without any great difficulty into the new world of the Vatican II liturgy, Giovanni Cardinal Montini of Milan was moving into his challenging new role as Pope Paul VI. As pope, he maintained his great support for and promotion of the liturgical reform he now had ultimate responsibility for implementing, and encouraged priests 'to do everything possible to educate the people to take an active part.'¹⁴ Paul VI candidly told a weekly general audience in April 1965, that they should not assume

...they will be allowed to return to the 'quiet, devout and lazy practices of the past'. He said the new approach must be different and 'must work to banish the passivity of the faithful present at Holy Mass. Before it was enough to assist, now we must participate. Before one's presence was enough. Now attention and action are required. Before some were able to doze and perhaps talk. Now this is not so. One must listen and pray.'¹⁵

Guilford Young was one of the bishops who worked closely with Pope Paul VI to draw up a blueprint for liturgical change¹⁶ and shepherd the church's transition into the major reforms being undertaken.

¹² Ibid., 211.

¹³ 'Pastoral Letter by Archbishop Young on Liturgy Reform,' *The Standard* (June 19, 1964): 3.

¹⁴ 'Pope Emphasises Hymn Importance,' *The Catholic Leader* (February 25, 1965): 11.

¹⁵ 'Mass 'Passivity' Trend Deplored,' *The Catholic Leader* (April 8, 1965): 11.

¹⁶ 'Liturgy Changes Show Confidence,' *The Catholic Leader* (May 27, 1965): 5.

1.1 Renewing the liturgy means renewing the Church

For Archbishop Young, renewing the liturgy was central to the process of renewing the entire church. In 1966 he said: 'I am convinced that the renewal to which the Church in the Second Council of the Vatican directed her energies will hinge on whether the presence and power of Christ in the dynamic mystery of the liturgy is unlocked to the minds and hearts and lives of the Christian community....'¹⁷

A contemporary of Guilford Young's on the Consilium was German liturgist Johannes Wagner, who was put in charge of the revision of the Roman Missal.¹⁸ According to Wagner Vatican II broke new ground with its central belief that 'a general movement for renewal of the Church is *derived from the liturgy*, draws its strength from public worship and makes the renewal of this worship its main purpose.'¹⁹ *Sacrosanctum Concilium* #2 encapsulates this notion, stating that the liturgy 'is the outstanding means whereby the faithful may express in their lives and manifest to others the mystery of Christ and the real nature of the true Church.' SC26 clarifies this by noting that 'liturgical services pertain to the whole body of the Church; they manifest it and have effects upon it.' Archbishop Guilford Young emphasised this point in 1965, writing that:

Slowly we are learning that Christ speaks to us through the Church and principally not by papal encyclicals or bishops' statements or 'what Father said,' but through the liturgy itself. It will take many years for the Word of God poured out by the liturgy to sink down and permeate our consciousness. It at least can happen now that the liturgy is in a language we can understand.²⁰

According to Johannes Wagner, the liturgy is the privileged medium via which the central realities of Christianity are encountered and experienced. Wagner specifies that 'when debating the schema on the liturgy the Council was already engaged on its theme *De Ecclesia*,²¹ and quotes Karl Rahner's view that 'in the liturgy the Church becomes an "event"', in the liturgy

...takes place the sacred *commercium* (exchange) of God with his chosen people: the Lord is in the midst of the gathering of those who are his own, and this gathering is holy precisely because he is in the midst of it. He gives himself to his own and they respond with thanksgiving and praise.²²

¹⁷ W.T. Southerwood, *The Wisdom of Guilford Young* (Georgetown TAS: Stella Maris, 1989), 344.

¹⁸ Piero Marini, *A Challenging Reform: Realizing the Vision of the Liturgical Renewal 1963-1975*, edited by Mark R. Francis, John R. Page and Keith F. Pecklers (Collegeville: The Liturgical Press, 2007), 8.

¹⁹ Ibid. Emphasis mine.

²⁰ Archbishop Young, 'English is merely the first step,' *The Standard* (Friday September 17, 1965): 7.

²¹ Wagner, 4.

²² Wagner, 3. No reference is included for the Rahner quote in Wagner's Preface.

If we take this notion seriously, we cannot help but understand that celebrating the Eucharistic liturgy is central to the very nature of the Church, and hence it *must* play a central role in the process of evangelisation and certainly in any form of new evangelisation. This point will be expanded upon below.

1.2 Establishing a new standard for liturgical celebration

In his promotion of the liturgy of Vatican II, Guilford Young identified a number of key issues that needed focused attention, careful study and persistence in practice if the liturgy was to be celebrated well. In a 1966 article in *Concilium: An International Review of Theology*,²³ Young identified three major liturgical challenges facing the Roman Catholic Church in Australia:

1. No tradition of devotion to the bible
2. No commonly known heritage of hymns
3. No experience of good preaching in terms of content or style.

Further comments and writing of Archbishop Young in other sources reveal the following liturgical priorities that could also easily have been added to this list:

4. The need for clear liturgical language: Young said: ‘Where language is obscure, then the face of Christ is concealed.’²⁴
5. The need for good performance practice: Young said that the way the liturgy is done in actual performance is crucial: ‘If not done properly, the inner meaning of the parts and of the whole will not come across.’²⁵
6. The authority of local episcopal conferences to adapt the liturgy to suit local conditions: Young wrote in 1963: ‘Already the trend to break away from complete control by Rome is obvious. The decree empowers regional conferences of bishops to adapt the liturgy to suit local conditions. Rome will merely confirm their decisions.’²⁶
7. The importance of the role of laity in the liturgy: Young said ‘It is a fundamental Catholic belief that the hierarchy cannot move without the laity. The head cannot move without the body.’²⁷
8. The need for diocesan liturgical commissions: Hobart had a functioning Diocesan Liturgical Commission as early as 1964, and in 1966 Young formed a pastoral council to ‘advise the Archbishop on matters affecting diocesan policy and implementation

²³ As reported in Southerwood, 319.

²⁴ Southerwood, 428.

²⁵ Southerwood, 452.

²⁶ ‘Archbishop Young Probes Decree on Liturgy,’ *The Standard* (December 27, 1963): 8.

²⁷ Archbishop Young, ‘English is merely the first step,’ *The Standard* (September 17, 1965): 7.

of Vatican Council decrees.' Every effort was made to ensure that its membership was truly representative.²⁸

9. The ongoing need for liturgical education: in 1966 Young engaged in a year-long teaching tour of Tasmania, doing much of the teaching himself and training a tutorial group to 'take over the major task of preparing the people of this archdiocese for the full impact of the Vatican Council which will renew the life of the Church throughout the world.'²⁹
10. The importance of regular communication between bishop, priests and people: During his time as Archbishop, Young wrote numerous articles in *The Standard* and took great pains to communicate his knowledge and explanations openly to the people of his Archdiocese.

There is much more to be said about the significance of Archbishop Guilford Young and his contribution to the liturgical life of the church in Australia, but a glimpse into the world of the late 1950s and early 1960s when the last major liturgical change took place is sufficient before considering today's changing scene and contemplating what a pioneer such as Archbishop Young might make of the liturgical situation in which we find ourselves today. Gaining an understanding of the church in the world and in 'the Australia' of 50 years ago is essential, because only by understanding our liturgical history, can we understand our liturgical present and speculate in an informed fashion about our potential liturgical futures.

Part II: Transcending Text

Those of us who like to spend our time reading liturgical documents and charting liturgical trends in the church have looked on in distress at times at the violations of proper ecclesiastical process and the misuse of power that has accompanied the production and implementation of the 2010 translation of the Roman Missal. Pentecost 2011 (June 12) saw its official introduction into Australian Roman Catholic parishes, and over the succeeding 19 months, this translation has gradually, stiltedly, uncomfortably become our way of praying. For some of us getting used to this translation has entailed a significant adjustment of our familiar patterns of prayer which has brought on a concatenation of emotion drawing us through shock, denial, anger, pain, bargaining and depression and toward reluctant acceptance, acquiescence, submission and obedience (in most cases), though some still struggle and resist the changes. Knowledge that there is little choice but to accept this translation has led many who find it difficult or awkward, to a position of 'emotional detachment' from the words of the liturgy. In a recent article in *Worship*, George B. Wilson wrote:

²⁸ Southerwood, 210.

²⁹ Southerwood, 311.

The texts we pray...are sacramental in nature. They open us to the action of the One who is uncreated grace. But that offer of healing and renewal is effective only to the extent that we are spiritually disposed to receive it. The new Roman missal, like every other sacramental reality, must be judged on its efficacy at evoking in the community the desire to hear the voice of the Lord and respond to it with gratitude and commitment.³⁰

The new liturgical words are at times alienating and seemingly deliberately chosen to emphasise the dissimilarity and distance between ourselves and God. At times, these new words *are* poetic, comprehensible and beautiful, but not consistently so. We could reiterate the many critiques and complaints made about the new translation, or we could try again to highlight those of its revisions which are valuable and worthwhile, but it seems that both of these thought tracks are now well-worn and to rehearse them again would just become wearisome. So, given the reality of an officially mandated text with which we shall have to live for the next few decades, where do we go from here? Does our liturgical focus remain trained on textual dissatisfaction and discomfort in something we cannot change, or might we find other more productive ways to focus our liturgical attention?

2.1 Perceiving Liturgy as Text

With the introduction of the most recent English translation of the Roman Missal in the Catholic Church, much of the public (and a fair portion of the scholarly) discourse on liturgy appears to have reverted for a time, to perceiving and focusing on liturgy primarily as text. In fact, a methodological assumption about the nature of liturgy itself underlies the approach taken to translating the Missal of Paul VI as revised by Pope John Paul II in 2002. This assumption is that essentially, liturgy equates to text, and thus could be retranslated in isolation from and largely irrespective of its ritual and performative context. As only minimal rubrical revisions accompanied the new translation [in the form of minor tweaks to the General Instruction of the Roman Missal (2010)], and the majority of the ritual action has remained unchanged, a focus on text among the scholarly appraisals of the new translation is unsurprising. What is surprising, however, is the fact that in a fit of academic nostalgia, much of the liturgical commentary on the new translation thus far has tended to sideline many of the advances made in liturgical methodology over the last 30 years or so; instead reverting back to a prior era of liturgical studies when the methodologies of philology, textual, redaction and source criticism, and comparative liturgiology³¹ dominated. While there is still most assuredly a place for such approaches to liturgical study, these

³⁰ George B. Wilson, 'Forum: But How Will the Introduction of the New Roman Missal Be *Evaluated*?' *Worship* 86/6 (November 2012): 551.

³¹ The chief proponent of this methodology was Anton Baumstark. See his *Comparative Liturgy* (Belgium: Chevetogne 1940, English translation London: Westminster, 1958).

approaches are limited as they remain largely two-dimensional while the lived-reality of liturgy is gloriously three-dimensional, performed by actual people, located in real-time, concrete space and myriad cultural contexts.

A methodological focal reversion which perceives liturgy primarily as text has seen a generalised side-stepping of some of the more difficult questions pertaining to the revised translation of the liturgy that are raised by engaging a holistic methodological study of liturgy as enacted rite. Accessing and evaluating the experiential data of performed liturgy (as opposed to analysing text on a page) has always presented difficulties to liturgical scholarship, but this should not mean that such approaches should be sidelined in our efforts to comprehend and research how the new translation is being received, whether and to what extent it works in practice or not, and what level of revision is recommended in order to make this translation more capable of communicating effectively the word of God to the people of God and enabling their authentic ritual and lived responses. It could be argued that in reality the only way to access this sort of information is to engage those messy and time-consuming social scientific methodologies such as surveys, focus-groups, interviews and the multiple methods employed in ritual studies, which would require moving beyond the safety and closed environment of textual analysis and into the unpredictable and open fields of human research. The real challenge of utilising social scientific methods in liturgical studies is that they entail giving credence to and taking seriously the authentic lived experience and opinions of real people: priest-presiders and assembly members, clerical and lay, expert and novice. Formal assessment of the workability, comprehensibility and ‘prayability’ of the new translation of the Mass via the crucible of its enacted performance by specific assemblies of worshipers, predictably has yet to have occurred on any significant scale.

2.2 A question of methodology

It could be argued that a methodological focal reversion to textual analysis is one of the unfortunate consequences to have emerged from the decision to place the task of revising the translation of the liturgy of Paul VI primarily into the hands of those trained not in the specialist history, literature, methods and social scientific approaches utilised in contemporary liturgical studies, but rather into the hands of those trained more generally as Latinists, scripture scholars or systematic theologians. Theological expertise is understood in terms of a scholar’s mastery of a particular body of literature and thought and their use of the methodologies developed for understanding, critiquing and applying that particular body of literature and thought. A lack of specifically *liturgical* methodological depth among the revisionists and translators responsible for producing the final text of the 2010 Roman Missal appears to have narrowed the understanding of liturgy to text and sidelined the integrally

related issues of performability, liturgical theology and practical concerns pertaining to the liturgy as enacted public prayer. Faced with the task of revising the translation of the Missal of Paul VI, it is not surprising that Latinists, scripture scholars and systematic theologians should revert to form, focusing on text (as their training has conditioned them to do) as a hermetically sealed two-dimensional entity which might make perfect sense in theory, but when enacted as performed ritual, as a living entity among existent diverse assemblies of worshipers, takes on vastly different dimensions and frequently fails in practice. This has been the experience of many of those trying to proclaim, receive and pray the overly long sentences, broken logic and convoluted attempts to maintain accuracy in translation at the expense of aural comprehension that are found frequently in this new translation.

2.3 Beyond the Text

So while the parameters of the discussion have been set thus far by those who understand and define liturgy primarily as text, I would suggest that it is time now for scholarly discourse on the new translation of the Mass to move beyond its myopic focus on text in isolation, and once again to take seriously the liturgy in its entirety as it is performed and prayed by real people, and not just in theory on the page.

As many as 26 years ago, Jewish liturgist Lawrence Hoffman pointed out in his book *Beyond the Text* that 'to study prayers as if they were inert literary specimens separable from the praying actors is not to comprehend their nature as prayers.'³² In this book, Hoffman defines liturgies as 'acted-out rituals involving prescribed texts, actions, timing, persons, and things, all coming together in a shared statement of communal identity by those who live with, through and by them.'³³ This is a good working definition of liturgy, and if we take seriously Hoffman's contention that liturgical scholars need to go beyond the text in order to comprehend liturgical prayer holistically, then alongside text and textual criticism we also need to engage in an extended and unemotional critique of the *enacted* meaning of the revised liturgy, taking a 360-degree view of it, transcending text alone in order to perceive the texts, actions, timing, persons, things, environment and sounds that *are* the liturgy in its entirety.

Vatican II called on the church to develop a liturgy that was clear, comprehensible, communal, culturally aware, engaging and unencumbered by useless repetitions, and while the text of the liturgy is central to enabling these aims, we need to ask whether 50 years on from the council we have come to rely on words too greatly in our liturgical celebrations, elevating them too far as the predominant vehicle of faith

³² Lawrence A. Hoffman, *Beyond the Text: A Holistic Approach to Liturgy* (Bloomington IN: Indiana University Press, 1987), 6-7.

³³ *Ibid.*, 3.

expression, while neglecting other vitally important facets of our rituals. Can we re-connect with the liturgy by transcending the text in order to reclaim and learn from some of the other modes of non-verbal participation utilised by Christians for centuries when the liturgy was prayed in a language most did not comprehend? Could a refocus on the other communication media of the liturgy help us today to re-engage ritually if the new texts of our liturgy fail to engage us?

PART III: THE POWER OF OTHER LITURGICAL MEDIA TO CONVEY PRESENCE AND COMMUNICATE THE FAITH

Vatican II's constitution on the sacred liturgy specifies that 'in the liturgy, by means of signs perceptible to the senses, human sanctification is signified and brought about in ways proper to each of these signs...' (SC7) In 1965, Archbishop Guilford Young explained that 'the Mass is a sacrament – something we should be able to see, hear, touch, taste, feel. It reveals God, not shrouds him.'³⁴ Both of these views offer encouragement to look beyond text alone when celebrating the liturgy.

For liturgical scholars, it is certainly not news to hear that good liturgy entails engaging all of the senses in our enactment of the ritual, and yet, how many times when liturgy is celebrated in parish contexts, do we really see an effort being made via good, carefully considered performance practice, to utilise all of the possibilities the liturgy offers to engage the senses and enable the rites done well to reveal the presence of God and communicate the faith? In general, alongside the significant work still to be done on the way in which the text of the liturgy is proclaimed and prayed, there is also room for much improvement in the performance practice of the non-textual aspects of the liturgy.

'Performance practice' is a term that comes from the field of musical performance, where techniques for performing specific musical genres from specific time periods are employed to facilitate accurate and authentic playing of that music. Examples of this would be the use of ornamentation in baroque music or the use of vibrato in some forms of jazz.³⁵ 'Performance practice' is a useful concept for us to consider in relation to the liturgy because it offers us a way of referring to the manner of celebrating the liturgy and to techniques that are implied, but not necessarily written down³⁶ or present in the rubrics. If our liturgical performance practice remains overly focused on the correct delivery of the text of the liturgy, and underplays the symbolic and ritual-action aspects of the liturgy or, even worse, utilises still further non-scripted words to explain the symbolic or ritual action (instead of just allowing the symbols and ritual actions to speak for themselves), we run the risk of robbing the ritual of its latent mystery or ambiguity and missing the opportunity to engage the religious ritual imaginations of our assemblies.

³⁴ Archbishop Young, 'English is merely the first step,' *The Standard* (Friday September 17, 1965): 7

³⁵ See: www.music.vt.edu/musicdictionary/textp/Performancepractice.html, accessed January 17, 2013.

³⁶ *Ibid.*

3.1 Shifting perceptions of 'presence'

In today's busy world, it may be the case that our perception of 'presence' and understanding of 'connection' are different from what they were 50 years ago. Today, technology has changed our sense of 'presence' with electronic media and especially social media providing an immediacy of connection anywhere at any time. With wifi and broadband, we are guaranteed immediacy of contact, instantaneousness of feedback/response/reaction, and with that, consequent expectations/preferences (particularly among younger generations) of non-stop entertainment, rapid shifts from one thing to the next. We have a different pace of speech, information access and processing; different rhythms of life (the 24-hour news cycle, late-night and weekend shopping, widespread shift-work, constant connection to the internet and friends/family through social media); we have different patterns of interaction/modes of connection than there were in the 1960s. As a consequence of this we also have a tendency toward impatience, a need for instant gratification, and an expectation of acknowledgment and reward for any effort exerted. In such a world, how is the presence of Christ to be recognised, experienced, communicated? A good place to start is by exploiting all of the communicative potential of the various media to which we have access in the liturgy, and doing all we can to make use of the liturgical sensorium.

3.2 Engaging the liturgical sensorium

If we are to engage all of the senses in liturgical celebration, we need to think about the liturgy in 360-degree terms. What does the assembly see, hear, taste, feel, and smell in the liturgy? Are those Powerpoint presentations we all seem to be addicted to really helping us to celebrate the liturgy better or are they hindering our celebrations in some ways? The human eye is drawn to movement and whatever moves in the liturgy attracts our eyes – so, if the Powerpoint slides are moving, that is where people's eyes are going to focus. If this communication medium is not used properly, we could inadvertently draw attention away from important liturgical action and toward unimportant Powerpoint slides. Are we going to permit the use of I-pads on the altar and in the pews as people begin to use e-missals rather than cumbersome books? What message is being conveyed by incorporating such technology into our ritual environments?

Are we engaging in aural bombardment of our assemblies with our use of the amplification systems in our churches? Is it too loud or squealing? Is it too soft? Do our liturgical presiders and ministers understand properly how to use the sound-system and microphones so that the presence of amplification is not noticeable rather than being an aural distraction to the assembly? I remember Fr. Michael Joncas saying

some years ago that we need to be aware that human beings do not have ear-flaps – we cannot just close our ears to sounds in the way that we can close our eyes to things we do not want to look at. Whenever someone has access to the amplification system during liturgy, for the assembly, there is no escaping from what that person says or sings into it. We need to ensure that the aural environment of liturgy is respected, and that only the very best and most worthwhile sounds are included and amplified.

Have we ever actually stopped to taste the bread and wine we serve in the liturgy? Do these really taste like the bread of heaven and the wine of salvation or do we simply just keep filling the order for the same stale bread and bland wine we have always used in the parish without stopping to consider that it is actually food for the tasting and wine for the drinking?

Do we use real flowers, real candles, real fire in our liturgies? Consider the use of fire in the liturgy celebrated to consecrate a new ritual space. During the rite of dedication a fire is lit on the altar. This is a particularly exciting moment in the liturgy because this is a rare act in our ritual vocabulary – generally, we do not intentionally set fire to the altar except in this rite, and this is a particularly powerful ritual action that awakens and arouses some of our most basic instincts. Fire evinces both fear and fascination in us and setting fire to the altar ought to make our heart-rates increase. We ought to be somewhat concerned that the living fire we bring into our ritual space might get out of control – this is something that cannot be simulated – genuine fire is essential for the ritual to evoke all of its inherent symbolic meanings. Using real symbolic elements fully and well in our liturgies should always be a priority in terms of good liturgical performance practice.

Another question to ask is: is the cheap and nasty incense really the best the parish can afford, or have we just not bothered to investigate the possibility of using good quality incense and thinking about changing it according to the liturgical season (why not consider using Frankincense during Christmas or Rose on Gaudete Sunday or Sage for cleansing during Lent?) Do our altar servers know how to light incense properly and use it appropriately in the ritual?³⁷ Our olfactory system has the capacity to convey a sense of presence, meaning and memory alongside all of our other senses, if only we stopped to think about how we can engage it fully.

When was the last time we considered the comfort of the chairs in which assemblies are required to spend so much of their time? Are the kneelers too close to the pews to be comfortable to kneel in? Are the pews too close together? Is the wood of the pews in need of sanding and repolishing so it that feels beautiful under the hands and knees? Are temporary plastic chairs really the best and most appropriate choice for our worship space?

³⁷ See: <http://www.youtube.com/watch?v=VVF7rOGHzIY>.

Have we taken the time to look around at the space and environment in which we worship to see whether there is any coherence in the objects, decorations, vestments, art, lighting, windows, and positioning of persons in relation to ritual action and assembly, or is there visual dissonance in our ritual spaces that generates a sense of subconscious disquiet which pushes us to spend much of the liturgy with our eyes closed so that we are not visually assaulted by what we see? Have we stopped to consider and watch the way in which we make ritual gestures? Is there room for improvement in our gestural and postural embodiment of the liturgy? How does time operate in our liturgical celebrations? Do we take too long on some parts of the liturgy while giving short shrift to others? The point of all of these questions is clear.

If we put our efforts into cultivating excellent, meaningful, reverent performance-practice of the liturgy through beautiful, well-played, appropriately-chosen music; through thoughtful, rich and well-proclaimed homilies; through the full use of our rituals' symbolic potential rather than the minimum we can get away with, then the actual text we are praying becomes less of a focus, less the be-all and end-all of the celebration.

3.3 The Distraction Factor

Liturgy performed poorly can test even the stoutest faith largely because of what I term the 'distraction factor.' The distraction factor in liturgy operates similarly to the distraction which occurs when someone switches on their mobile phone in the cinema during a movie. When this happens, the light from the mobile phone screen draws attention away from the movie screen and suddenly the viewer is pulled out of the 'world' or 'atmosphere' of the movie and back into the reality of the movie theatre, losing momentarily their rapport with the 'world' of the movie they were enjoying before their attention was diverted by something that has no place a movie theatre. Similarly, when elements of liturgy are ill-prepared, stumbled over or poorly executed, one's attention can become drawn toward the person responsible for disrupting the ritual flow and away from the liturgical action. The problem with this type of distraction is that rather than just moving one from movie-world into reality, in the liturgy, one's attention is being drawn away from the paschal mystery unfolding anew in the liturgy and toward the mundane. If the 'distraction factor' in liturgy can test even the stoutest of faith, then what is it going to do to nascent faith, waning faith, and faith being questioned or tested?

An ongoing challenge for liturgists is to ensure the minimisation of distractions in the liturgy by knowing the church's teaching on how liturgy should be celebrated ideally, by thinking through what are the likely distractions and eliminating them as far as possible, and by ensuring that those who are chosen to serve in the various

roles of the liturgy are the most appropriate persons to undertake those roles, that they are properly trained and capable of understanding the responsibility with which they have been entrusted and that they undertake this service on behalf of the community with the primary purpose of facilitating the community's prayer to God.

If the liturgy is the medium via which we encounter God and the medium performed poorly becomes a means of distracting us from the message/encounter/relationship being built or reinforced or nurtured, then there is a problem in the manner in which the message is being received, a problem of reception, an interruption of smooth communication. It is important to minimise the 'distraction factor' as much as possible in the celebration of liturgy.

Part IV: The role of liturgy in the new evangelisation

That the liturgy is at the centre of what it is to be church is a notion that many contemporary Christians need to rediscover or in some cases, discover for the first time. The assumption that those who have been baptised have actually heard and accepted the faith can no longer be made. Research³⁸ demonstrates that a notable level of religious illiteracy, apathy and disinterest is prevalent among a majority of younger Christians, even those who have been educated in Christian schools. For many younger Christians, it is not necessarily that they have heard the message of Christ and actively turned away from it to embrace other consciously chosen religious paths, rather what is more likely, is that they have gradually drifted away from practicing their Christian faith in many cases because they have never been taught the message of Christ properly or fully, or they have not heard it preached in a way that makes sense to them and ignites and keeps burning the fire of faith in their young adult lives.

A challenge with younger generations is that by and large, they do not share the same mentality as middle-aged and older Christians regarding the necessity of attending liturgy on a regular basis, and if when they do attend liturgy, they find it boring, not well prepared, or not well performed, there is a strong likelihood that they will not return. A major generational difference also, is that in the main, they will not feel guilty about not returning. There is no shame attached to non-attendance at church among younger Christians today.

In the Australia of the 1950s and 1960s there was no question that to be a Christian meant that one would attend church regularly – this was both an ecclesial and a cultural expectation. Today, with weekly church attendance in the Roman Catholic

³⁸ See: Michael Mason, Ruth Webber, Andrew Singleton and Philip Hughes, "The Spirit of Generation Y: Young People's Spirituality in a Changing Australia." <http://dlibrary.acu.edu.au/research/ccls/sppub/sppub.htm>, last accessed January 20, 2013.

denomination down to 13.8%³⁹ of self-identified Catholics, clearly things have changed. Church attendance, participation in the liturgy, and taking one's place amidst the body of Christ gathered to worship God do not seem to hold the same meaning for many of today's Christians as they once did.

4.1 New evangelisation

Pope John Paul II introduced the notion of the 'new evangelisation'⁴⁰ when he recognised a need to reawaken the Christian faith in parts of the world which had been evangelised or converted to Christianity many centuries earlier (especially in Europe), and which were considered traditionally or culturally Christian. John Paul II explained that what was new about the new evangelisation was that it would be 'new in ardour, in method and expression.'⁴¹ Throughout his tenure as pope, John Paul II continued to explore and explain this notion of a new evangelisation⁴² and under the leadership of his successor, Pope Benedict XVI, the call to a new evangelisation has been taken up with a renewed vigour and urgency⁴³ as the rapidly changing contemporary world and its processes of secularisation have challenged the Roman Catholic tradition and the Christian approach to life in ways not seen before. In 2010, Benedict XVI outlined 5 specific aims for this new Pontifical Council,⁴⁴ but surprisingly among them there is no mention of the role to be played by liturgy in the process of new evangelisation. However, in October 2012 at the conclusion of the Synod of Bishops, Pope Benedict XVI spoke of the need for new evangelisation in the lives of 'the baptised whose lives do not reflect the demands of Baptism,' and said that the Church is particularly concerned 'that they should encounter Jesus Christ

³⁹ This data comes from The National Church Life Survey which reports that in 2006 13.8% of Catholics attended Mass on a weekly basis. http://www.ppo.catholic.org.au/pdf/SummaryReport_MassAttendanceInAustralia.pdf, last accessed October 24, 2011.

⁴⁰ Pope John Paul II's first extended discourse on this concept came in an address to the Latin American Bishops in Haiti in 1983. See: http://www.vatican.va/holy_father/john_paul_ii/speeches/1983/march/documents/hf_jp-ii_spe_19830309_assemblea-celam_it.html, last accessed January 15, 2013.

⁴¹ John Paul II, Discourse to the XIX Assembly of C.E.L.A.M. (9 March 1983), 3: *L'Osservatore Romano*: Weekly Edition in English, 18 April 1983, p. 9: AAS 75 (1983) 778.

⁴² An extended expression of John Paul II's teaching on this matter can be found in his Apostolic Letter *Novo Millennio Ineunte*, 'At the beginning of the third millennium,' on the occasion of the end of the Jubilee Year 2000, January 6, 2001. http://www.vatican.va/holy_father/john_paul_ii/apost_letters/documents/hf_jp-ii_apl_20010106_novo-millennio-ineunte_en.html, last accessed January 15, 2013. Also of significance in relation to John Paul II's call to new evangelisation is his Post-Synodal Apostolic Exhortation, *Christifidelis Laici*, on the vocation and mission of the lay faithful in the church and in the world, (December 30, 1988), see especially articles 4, 30, 33, 34, 35, 49, 64. http://www.vatican.va/holy_father/john_paul_ii/apost_exhortations/documents/hf_jp-ii_exh_30121988_christifideles-laici_en.html, last accessed January 15, 2013.

⁴³ Pope Benedict XVI has gone so far as to establish a Pontifical Council for Promoting the New Evangelisation. See: Pope Benedict XVI, *Motu Proprio*, 'Ubicumque et Semper', September 21, 2010, http://www.vatican.va/holy_father/benedict_xvi/apost_letters/documents/hf_ben-xvi_apl_20100921_ubicumque-et-semper_en.html, last accessed January 15, 2013.

⁴⁴ These aims are: to examine the theological and pastoral meaning of the new evangelisation; promote and foster the study, dissemination and implementation of the Papal Magisterium on the new evangelisation; to make known and support initiatives linked to the new evangelisation; to study and encourage the use of modern forms of communication as instruments for the new evangelisation and to promote the use of the Catechism of the Catholic Church as an essential and complete formulation of the content of the faith for the people of our time. See the *motu proprio* 'Ubicumque et Semper,' for details.

anew, rediscover the joy of faith and return to religious practice in the community of the faithful.⁴⁵ New evangelisation is not about conveying a new message – the message has not changed. What is new about it is the manner, medium and method of conveying the one message of Christ's Gospel both for those who have not heard it and for those who have, but who may have lost interest or never really received the message in the first hearing.

4.2 Liturgy as medium of evangelisation

It seems obvious to state that when the Church speaks of 'new evangelisation,' surely the notion that the liturgy is at the heart of the church and that being a member of the church means participating in the liturgy on a regular basis, ought to be central. This was certainly the belief expressed in *Sacrosanctum Concilium* 9, which directly links liturgy and evangelisation.⁴⁶ So how can the liturgy play a leading role in fostering a new evangelization? Liturgy is the primary medium for the Word of God, the Gospel which is in need of communication to the next generation alongside current generations of Christians. Liturgy can certainly serve as a primary medium of evangelisation by communicating the central tenets of the Christian faith in ways that can be heard, understood, digested and acted upon in life. Those who are life-long practicing Christians know the difference between attending a liturgy that is performed well and enduring a liturgy that is performed poorly. The first type feeds and nourishes the spirit and one is energised by one's partaking of the feast of Word and sacrament beautifully prepared, served and consumed. The other gets the job done, fulfils an obligation but leaves one with a feeling of dissatisfaction and sometimes even just relief that it is over. While we can survive on a diet of poor liturgy, the question remains of whether we run the risk of spiritual malnutrition if we attempt to live on a diet of poor liturgy consistently.

The liturgy of Vatican II performed properly and celebrated well by embracing fully all of its' communicative, connective, aesthetic and sensorially affective potential can play a major role in igniting and maintaining the fire of faith among Christians today. The power of ritual performed well, effective and dynamic leadership of the presider, a sense of belonging to a vibrant worship community, the richness of symbols used lavishly, the excellence and beauty of music, the demonstrable faith of well-trained lectors, cantors, ministers of Holy Communion, etc. can all serve in the task of evangelisation accomplished through the liturgy.

⁴⁵ Pope Benedict XVI, Homily at the Concluding Mass of the Synod of Bishops, (October 28, 2012). <http://www.zenit.org/article-35830?l=english>

⁴⁶ SC9 states: 'Before people can come to the liturgy they must be called to faith and to conversion: 'How then are they to call upon him in whom they have not yet believed? But how are they to believe him whom they have not heard? And how are they to hear if no one preached? And how are men to preach unless they be sent?' (Rom 10:14-15). Therefore the Church announces the good tidings of salvation to those who do not believe, so that all may know the true God and Jesus Christ whom he has sent and may be converted from their ways, doing penance. To believers, also, the Church must ever preach faith and penance, prepare them for the sacraments, teach them to observe all that Christ has commanded, and invite them to all the works of charity, worship, and the apostolate.'

http://www.vatican.va/archive/hist_councils/ii_vatican_council/documents/vat-ii_const_19631204_sacrosanctum-concilium_en.html, accessed January 17, 2013.

CONCLUSION

If we were to ask whether Archbishop Guilford Young's expectations for a liturgy-led renewal of the church have been realised 50 years after Vatican II, the answer would be both yes and no. His ten liturgical priorities (considered earlier) have been met to an extent, some more than others. Today, among Catholics, there is better devotion to and knowledge of the Bible in some ways than there was in the mid-1960s; there is a repertoire of commonly known hymns (whether many of these can be considered to be good music or liturgically appropriate is up for discussion). In pockets there is good preaching in terms of content and style, but there is still a long way to go before good preaching can be seen in a majority of parishes a majority of the time. Whether the new translation of the Mass can be said to constitute clear liturgical language is debatable. In many parishes, there is much room for improvement in terms of fostering good liturgical performance practice. The authority of local episcopal conferences to adapt the liturgy to suit local conditions has been severely compromised by the current trend toward Roman centralisation and over-regulation in all liturgical matters. I believe Archbishop Young would have been very pleased to see the way in which the laity have taken up and embraced with enthusiasm their roles in the liturgy both as members of an active assembly and as liturgical ministers. One imagines Young would be quite disappointed to see the state of many of Australia's diocesan liturgical commissions today: while in some dioceses they continue to operate effectively, in other dioceses they have been discontinued altogether. Archbishop Young would likely be pleased with the number of opportunities available to people today to become further educated in liturgical matters, but he would probably also be advocating for more people to avail themselves of these opportunities, and for the Australian bishops to encourage much more of a focus on the study of liturgy in seminaries, universities and theologates than we have at present. One imagines that Archbishop Young would have encouraged bishops to make far greater use of the opportunities offered by today's social media to communicate regularly their knowledge, wisdom and explanations of the faith to and with their priests and people.

It is appropriate to conclude with a final word from Archbishop Sir Guilford Young, whose wisdom holds remarkable relevance still today. In 1965 he said:

We still have a long way to go before our people find that the liturgy is a perfect expression of their faith.... But just getting familiar with the Mass text is far from becoming the sort of Catholic the Vatican Council's liturgy revolution is supposed to produce. We have to go much deeper and become conscious of the liturgy for what it is – God here and now intervening in history in a direct and immediate manner.⁴⁷

⁴⁷ Archbishop Young, 'English is merely the first step,' *The Standard* (September 17, 1965): 7.

Liturgy and Sound

Peter Williams



Fr Peter Williams is a priest of the Catholic Diocese of Parramatta and is currently Vicar General and Director of the Office for Worship. For eleven years he was Executive Secretary of the Bishops Commission for Liturgy of the Australian Catholic Bishops Conference. He teaches liturgy at the Catholic Institute of Sydney.

Sound or rather the various sounds associated with liturgical praxis are at the very heart of what we do in the business of worship. In literal terms sound is defined as ‘a mechanical wave that is an oscillation of pressure transmitted through a solid, liquid, or gas, composed of frequencies within the range of hearing.’⁴⁸ But as the noted psychologist of music Paul Davies reminds us: ‘Sound as such, does not really exist in the world around us. What does exist is vibration... In other words, there is no sound until we hear it.’⁴⁹ For the purposes of this paper I will divide the ‘sound’ of liturgy into three components – speech, music, and of course silence which also constitutes ‘sound.’

In his book *Ritual Music*, Edward Foley makes five observations about the nature of sound which we shall consider in turn.

First, one of the characteristics of sound events is their transitory nature. Sound events cannot stay the same. Secondly, closely related to the impermanence of the sound event is the intangibility of the sound phenomenon. The experience of the intangibility of sound phenomena is heightened by the fact that they are perceptible by one sense – they are only heard. Thirdly, sound events are perceived as active, dynamic experiences in comparison with visual events which can more easily give the subject the illusion of having taken part in a passive, disengaged activity. Fourthly, sound events are essentially acts of engagement. The human ear has no natural covering, it is born open to every sound. Fifthly, sound encounters are keyed to be personal encounters.⁵⁰ With these observations in mind then, let us consider the first sound event of liturgy.

⁴⁸ The American Heritage Dictionary of the English Language, Fourth Edition (Houghton Mifflin Company, 2000.)

⁴⁹ *Ritual Music – Studies in Liturgical Musicology*, Edward Foley, (The Pastoral Press:Beltsville,1995) 109.

⁵⁰ *Ritual Music*, Foley, 110-111

SPEECH:

Speech is ostensibly about words, and in the context of worship is about particular words, or one might even suggest a particular language. The speech of liturgy can be formal, informal, written, or extemporised. It can and often is drawn from a sacred source, and for Christians much recourse is made to the words contained in Sacred Scripture. What is the sound of words in speech attempting to achieve within the context of liturgy?

For our purposes we can divide liturgical speech into prayers, scripture and homily/sermon. In some traditions there is also a dialogue which occurs between the presiding minister and the assembly. Within any worship service there is also instruction (as to posture to be adopted or what is to be sung and when) and the provision of information (parish notices and ad lib community announcements). Here I will only treat prayers, scripture and the homily/sermon without negating the significance of dialogue, instruction or information in singling out these three.

Let us consider each one in turn.

1. PRAYERS

Prayers are the core of worship. They attempt to articulate matters that pertain to exploring and defining our relationship with God, and as a consequence our relationship with those who share in the same belief. In the Christian framework prayers have traditionally been addressed to God, through Jesus Christ and in the power of the Holy Spirit. Thus already it can be seen that prayer has a dynamic element to it, because it is above all relational – our relationship with to God made manifest in a Trinity of persons, to use the classical language. What should that prayer express? It can express praise, it can implore God to act, it can express lament, it can sometimes express anger and bewilderment. Prayer is a vehicle that can convey a multiplicity of emotions and at the same time express profound truth. The sound of prayer can be familiar if that prayer is written, but even if extempore, prayer has a particular formula that is immediately recognised by the worshipper. The congregation by virtue of its presence in the liturgical assembly is invited to participate and ‘own’ the words that are spoken in prayer by its assent with the ‘Amen.’ This type of prayer is often spoken (though in some traditions it is chanted) on the assembly’s behalf by another. There are also times in liturgy where speech is corporate – when a text is expressed by the whole congregation. The sound of the voices in unison evokes a different response. When making creedal statements there is an implied public dimension to the ownership of the words, of the spoken text.

Who controls the content of the prayer that becomes ‘holy’ speech? This can be a contentious matter, particularly if one adheres to the Latin dictum: *Lex orandi, lex*

credendi – what we pray is what we believe. In liturgical churches the content of the prayer has in many instances been handed down from one generation to another within a liturgical deposit. Its origin has sometimes been in another language and requires translation. In other instances written prayers have been handed down over the centuries in the original language of the worshippers, or are modern compositions that respond to the time and places which we now inhabit. How much of prayer should express the past? How much of our prayer should express the present? Is the content of prayer timeless? Do we hear the prayer differently in a formal or informal setting?

Within the Christian tradition we aim to rehearse in our liturgical prayer the mystery of the person of Jesus Christ, and our incorporation into that mystery by the grace of baptism. Our relationship with God and each other is sustained by our coming together in Christian assembly to worship God and express thanks for our incorporation into Christ. Within our various traditions this either takes the form of a Eucharistic celebration or a celebration that focuses on the proclamation of the Word of God. The component parts of that formal liturgy (whether a Eucharist or a Liturgy of the Word) will have elements of speech that are repetitive and elements that vary. What of the words – the speech that is repetitive? Do we always hear that speech, those words in the same way? One of the hallmarks of a defined and repetitive liturgy (at least in the minds of those who champion that form) is that it provides stability, or as one commentator has said ‘safety.’⁵¹ If that is the case then how do we hear that speech, those words? Are the words that are spoken confronting, cajoling, comforting, benign or perhaps even boring? Should prayer be used for promoting a particular agenda, an ideological platform? Should prayer be subversive? The words of prayer that become speech in a liturgical rite carry great power. The formalism of the setting in which the words are spoken can imply a degree of authority that is often embodied in the one who speaks on behalf of the gathered assembly. Does that also imply a sacred character to the one authorised to lead the assembly and pray in its name?

2. Scripture

Ancient documents on the liturgy remind us that the reading of Scripture is constituent to the act of worship, for scripture proclaimed in an act of worship bears its own authority as the word of God, which is to be heard reverently, pondered reflectively, and actualised in the life of the believer.

In the *Constitution on the Sacred Liturgy* from the Second Vatican Council the following paragraph underscores the significance of Sacred Scripture in a liturgical framework for Roman Catholics and other liturgical churches.

⁵¹ Canon Alan Griffiths in ‘Become One Body, One Spirit in Christ’ CD-DVD ICEL 2010.

Sacred Scripture is of the greatest importance in the celebration of the liturgy. For it is from Scripture that the readings are given and explained in the homily and that psalms are sung; the prayers, collects, and liturgical songs are scriptural in their inspiration; it is from the Scriptures that actions and signs derive their meaning. Thus to achieve the reform, progress, and adaptation of the liturgy, it is essential to promote that warm and living love for Scripture to which the venerable tradition of both Eastern and Western rites give testimony. (SC 24)⁵²

When the three year Lectionary for Mass was published in 1969 the General Introduction expanded on the place of the Word of God in liturgical celebrations when it stated:

In the celebration of the liturgy the word of God is not voiced in only one way nor does it always stir the hearts of the hearers with the same power, Always, however, Christ is present in his word; as he carries out the mystery of salvation, he sanctifies us and offers the Father perfect worship. Moreover, the word of God unceasingly calls to mind and extends the plan of salvation, which achieves its fullest expression in the liturgy. The liturgical celebration becomes therefore the continuing, complete, and effective presentation of God's word. That word constantly proclaimed in the liturgy is always, then, a living, active word through the power of the Holy Spirit. It expresses the Father's love that never fails in its effectiveness toward us. (LM GI 2 a. 4)⁵³

Certain questions emerge about the Scripture as 'sound' in liturgy. Who is responsible for choosing the pericopes which make up the Biblical texts? What translation of that text is employed and on what basis is that choice made? Does the disposition of the reader and their gender make a difference to the way that the Word is heard and received? Do we hear parts of the Scripture differently depending on context? Is more credence given to readings from the New Testament rather than the Hebrew Scriptures? Do certain passages of Scripture offend when read? Should the passages of Scripture proclaimed challenge and disturb? Does a reading make us angry? Does the Scripture propel us into action? Because it is the Word of God are we more attentive to its proclamation than other parts of the liturgy? As a general rule the assembly is quite passive during the reading of the Word of God. Does sitting and standing affect the way we hear?

The reading and hearing of the word of God is a principal source of sustenance in all liturgical acts. For those traditions that focus on the word of God in their Sunday worship it is the principal nourishment, and for those traditions where the Liturgy of the Word is in juxtaposition to the Liturgy of the Eucharist – the two modes happily complement and mutually inform.

⁵² The Liturgy Documents: A Parish Resource, (LTP:Chicago, 1991),14.

⁵³ Ibid., 118.

Once again the General Introduction to the Lectionary expresses this well:

The Church is nourished spiritually at the table of God's word and at the table of the eucharist: from the one it grows in wisdom and from the other in holiness. In the word of God the divine covenant is announced; in the eucharist the new and everlasting covenant is renewed. The spoken word of God brings to mind the history of salvation; the eucharist embodies it in the sacramental signs of the liturgy. (LM GI 3 d. 10)⁵⁴

3. Homily/Sermon

In the document published by the US Catholic Bishops entitled 'Fulfilled in your hearing' the following is said:

The person who preaches in the context of the liturgical assembly is a mediator, representing both the community and the Lord. The assembly gathers for liturgy as a community of faith, believing that God has acted in human history and more particularly, in their own history... The preacher acts as a mediator, making connections between the real lives of people who believe in Jesus Christ but are not always sure what difference faith can make in their lives, and the God who calls us into ever deeper communion with himself and with one another. (12)(14)⁵⁵

Traditionally the principal source for the homily/sermon at worship has been the Sacred Scripture. Because the homily/sermon is a unique text for the preacher, whether it is written or extempore, it has inherent risks. The words preached will be heard differently by every member of the assembly. The effect of the homily/sermon is difficult to calculate and there is no objective tool of measurement for the 'success' or otherwise of a homily/sermon. And like the content of prayer or Sacred Scripture the words (and sometimes actions) of the homily/sermon can console, alienate, confirm, disturb, induce laughter, reduce to tears, inspire or reduce confidence. The speech of the homily/sermon is capable both of reassuring the believer of the love of God, or conversely, leading the worshipper into an acute sense of guilt or unworthiness. It is a powerful instrument of communication and within many Christian traditions is heard without comment or interruption from the assembly. In those liturgical traditions where the orations and the scripture readings are fixed and repeated year after year the homily/sermon stands out as the one variable, and thus is of enormous significance in the experience of the worshipper. In those traditions where the word preached is of central importance it is the core element of the liturgy. Again questions emerge about the homily/sermon – who is entitled to preach? Should homilies/sermons be written texts or extemporised? Is there an optimum length? Should homilies/sermons always find their inspiration in the word of God?

⁵⁴ Ibid., 118.

⁵⁵ Ibid., 351-352.

MUSIC:

'And after they had sung the hymn, they went out to the Mount of Olives' (Matt 26:30). So it is recorded in the Gospel of Matthew at the conclusion of the Last Supper. Music, the use of the human voice in praise of God together with musical instruments, was an integral part of the worship of the Temple in Judaism and was carried over into the worship of the early Christian Church. St Paul in both Ephesians and Colossians exhorts the assembly to sing 'as you sing psalms and hymns and spiritual songs among yourselves, singing and making melody to the Lord in your heart' (Eph 5.19). 'Let the word of Christ dwell in you richly; teach and admonish one another in all wisdom; and with gratitude in your hearts sing psalms, hymns, and spiritual songs to God.' (Col 3:16) There are other references to the use of song in worship in the New Testament – principally in the Book of Revelation . There is a rich history of the use and development of music in Christian worship – some of that music stands amongst the most famous and inspiring of the classical Western repertoire, while other worship music been lost over the passing of time. There remain many vexed questions about the place of music, its role, its content, and its style in Christian worship.

The Roman Catholic Church until the Second Vatican Council held that there was a 'sacred' quality to the music that was employed in the liturgy. This idea was expressed principally in the *Motu Proprio* of Pius X *Tra le sollecitudini* which states in part:

It must be holy, and therefore avoid everything that is secular, both in itself and in the way it is performed. It must really be an art, since in no other way can it have on the mind of those who hear it the effect which the Church desires in using in her liturgy the art of sound.

The *Constitution on the Sacred Liturgy* of the Second Vatican Council says:

The musical tradition of the universal Church is a treasure of inestimable value, greater than that of any other art. The main reason for this pre-eminence is that, as sacred song closely bound to the text; it forms a necessary or integral part of the solemn liturgy. (SC 112)

But then in paragraphs 118 and 119 the Constitution commends 'people's own religious songs' and 'people who have their own musical traditions.' These paragraphs have been broadly interpreted since the Council as providing license for any and all musical styles to be used in liturgical celebrations.

This 'liberalisation' has not only had a profound effect on Catholic liturgical music but it has also spilled over into the other mainline liturgical churches with what amounts to an almost revolutionary change in musical style and 'ownership' since the 1960s.

As a vehicle to transmit Divine truths and to express the longing of the human heart in the search for God, music has no rival.

The successful appropriation by the Pentecostal churches of contemporary song (which has always been a feature of their worship style) and in particular the rise of Christian 'rock' and the Hillsong phenomenon has raised questions for clergy and liturgical musicians in every tradition as they discern what is the right musical sound for worship. For Christian traditions that remain locked into more ancient forms of chant and a received musical idiom that finds its locus in a particular culture, these questions remain at the periphery of their liturgical life.

Perhaps the broader question to be asked is: does the liturgical context render a musical composition sacred, or is there an inherent sacredness by virtue of the text and the musical style? Or, does it not matter at all whether the tag 'sacred' is applied? Historians of liturgical music will tell you that over the centuries the Church appropriated the songs of the people from the taverns and village celebrations and 'sacralised' them. One only has to think of the enormous success of the German chorale at the time of Martin Luther championed by J.S. Bach to understand how successful such an adaptation can be.

But there still remains the question of the 'sound' of music within a ritual context. There is little doubt even from the most cursory of observation that music used in worship can have a far reaching effect upon the hearts and minds of the worshippers. As a vehicle to transmit Divine truths and to express the longing of the human heart in the search for God, music has no rival. Coupled with ritual action (even at its most rudimentary) music is transformative, and no matter how beautifully crafted an oration or homily preached by the most skilful of preachers, music cannot be matched in terms of liturgical sound.

Music in liturgy is also a potent force in terms of religious memory. Melodies remain fixed in people's minds from childhood and last for the whole of life. The sound of a particular hymn, song, chorus, and chant – in fact any form can arouse in the worshipper a vivid connection with the past. Music can be a 'paschal' moment, truly an experience of anamnesis that should not be underestimated as a source of sustenance for maintaining and building faith.

The function of music in certain liturgical traditions is ministerial – that is, it serves to bring the worshipper into more substantive involvement in the liturgical act. For those mainstream liturgical churches which have a fixed liturgical form, the music is the most variable aspect of the celebration. Whilst the Scripture readings and certain of the prayers vary Sunday by Sunday, the musical elements admit a variability that is determined by the performer (s) the hearer (s) and the context in which it takes

place. The performance of liturgical music can be participatory in different ways. The contribution of a choir, or a schola, a cantor, a band of musicians, an organist, a keyboard player, and the individual worshipper who joins in the song will produce a body of sound that will always generate a new experience because such performances cannot be replicated in the same way even if the same repertoire is chosen. If the person leading the liturgical celebration (and others in liturgical leadership roles) uses their singing voice as part of the celebration, what is heard in terms of liturgical sound will be quite different from what is spoken as speech.

Within the reformed tradition, the singing of hymns, choruses and spiritual songs has had a central place in the act of worship. It has been said of the Methodists that they sang their doctrine in the form of the great corpus of classic metrical hymnody that came from the pen of Charles Wesley. For Anglicans the vast treasury of a choral repertoire mainly but not exclusively championed by Cathedral and Collegiate establishments, has produced a unique liturgical musical culture inspired by that master craftsman of the English language Thomas Cramner, can draw the listener into an ethereal experience unmatched in the Western Church. The reliance on singing the psalms as the principal source of music in the worship of the Church of Scotland and the Presbyterian Church also has enriched other traditions. The Roman Catholic Church has for centuries expressed itself in Gregorian chant and in forms of polyphony, and over the centuries has engaged some of the most famous composers in classical music to write for its liturgical celebrations. In more recent times we have become aware of the diverse musical forms in the Churches of the East which have found a place in the religious landscape of Australia. All these various musical forms add a rich texture to the aural experience of the worshipper in a multiplicity of ways as they enter and participate in worship.

What has emerged in recent decades has been an ecumenical sharing of liturgical, religious and sacred music across denominational boundaries. You can hear Gregorian chant in a Uniting Church, hymns of Charles Wesley in a Catholic Mass, choruses from Moody and Sankey in an Anglican Church, Anglican chant in a Lutheran church. This cross fertilisation has probably been one of the greatest gains in the ecumenical endeavour.

But of course many questions remain, and the place, the role, the choice of music in our liturgical and non-liturgical churches are issues that remain high on the agenda. What texts should be sung? Who should regulate those texts? Who should sing those texts? Should the music that accompanies the text be contemporary and emerge from the local culture? Is there no place for musical idioms that represent the past? Are all musical instruments suitable for Divine Worship? And what of the singing voice of the assembly – should that voice be the predominant expression of liturgical song?

Should music be in the hands only of those who are trained and constitute a distinct group within a celebration? Should particular standards of musical competence be set to regulate the music that is heard and participated in during acts of worship? How much should contemporary 'taste cultures' determine the sound of what is heard in our liturgies?

These questions are constantly being debated because there are no easy answers to them. In large measure the sound of music in our liturgies is, and will remain highly subjective because of the individual nature of each person who constitutes the assembly.

SILENCE:

*Hello darkness, my old friend
I've come to talk with you again
Because a vision softly creeping
Left its seeds while I was sleeping
And the vision that was planted in my brain
Still remains
Within the sound of silence*

The words of the first verse of the Simon and Garfunkel song 'Sound of Silence' will be familiar to some and it begs the question: Does silence have a sound? The classic definition of silence would suggest that it does.

Silence is the lack of audible sound or presence of sounds of very low intensity. By analogy, the word silence can also refer to any absence of communication, including in media other than speech. Silence is also used as total communication, in reference to non-verbal communication and spiritual connection. Silence also refers to no sounds uttered by anybody in a room or area. Silence is an important factor in many cultural spectacles, as in rituals.⁵⁶

The fact of in-audibility does not imply lack of sound. And as the definition suggests silence is particularly powerful as an accompaniment to religious ritual.

Perhaps the key text in the Bible about the significance of silence and encounter with the Divine is found in I Kings 19 in the familiar passage about Elijah.

Now there was a great wind, so strong that it was splitting mountains and breaking rocks in pieces before the Lord, but the Lord was not in the wind; and after the wind an earthquake, but the Lord was not in the earthquake; and after the earthquake a fire, but

⁵⁶ <http://dictionary.reference.com/browse/silence>

**'Sacred silence'
implies a
particular
quality that
distinguishes
such silence
from other
settings.**

the Lord was not in the fire; and after the fire a sound of sheer silence. When Elijah heard it, he wrapped his face in his mantle and went out and stood at the entrance of the cave. (NRSV)

In Christian worship, silence is indispensable as a tool of communication as it provides a space where sung and spoken sounds can be interiorised and appropriated at the deepest level. It comes as no surprise that in the rubrics of various liturgies silence is suggested or even mandated, and silence has been referred to as 'sacred silence' which implies a particular quality that distinguishes such silence from that found in other settings. In the revised GIRM (#45), we read,

'Sacred silence also, as part of the celebration, is to be observed at the designated times.' This means that silence is an integral and important part of every liturgy. It is called 'sacred' for in this silence we meet God, the Holy One. We also meet there the holiness to which each of us is called by our baptism.

It comes as no surprise that silence is a constituent element in many of the world's major religions and much has been written about silence and how to use it most effectively. Mention was made earlier of the association of silence with ritual. Ceremonial action can take place in silence while the visual element assists in stimulating the religious imagination and drawing people into the ritual moment without the need of verbal explanation – but there are also times liturgically when there is no ceremonial action, but rather the silent solidarity of the assembly sitting, standing or kneeling and simply being still. As one pastor wrote in providing catechesis on silence for his congregation:

Silence is not an absence of noise, but rather, sacred quiet which opens us to God's Spirit. It is out of such moments that God can really get through to us and move us to truly uplifting vocal praise and song. These silent moments serve to embrace and emphasize the words or phrases that went before. It allows us a chance to catch our breath. Silent pauses allow us to reflect on what we are really doing. It gives us a chance to listen to God in our heart.⁵⁷

There are real challenges here so that silence seamlessly flows as part of the liturgical structure and does not give the impression that it is imposed, and thus artificial. How is silence to be controlled? Who makes the determination as to how long silence is to be maintained? Is it appropriate that some form of instruction precede silence so that people 'know what to do?' As with music silence can be a most potent tool in liturgical praxis and there will inevitably be questions about its location and use in the rite.

⁵⁷ <http://www.mikejohnpat.org/index.cfm/our-liturgy-and-silence/>

CONCLUSION

I think we can see that the subject of liturgy and sound is both a complex and compelling dynamic in the science of worship. It will forever be undergoing change and review because of the transitory nature of acts of worship. Because all three elements (speech, music and silence) are reliant on the participation of human beings, and because those same human beings set the boundaries, create the words, compose the music and preside over the ritual even what may appear on the surface as a predictable and easily identifiable religious ritual, is in reality, very far removed from the static enterprise that many think constitutes Christian worship.

My hope would be that many of the questions raised in this paper might be the source of further reflection so that those who have responsibility for crafting and enacting our worship may be led into a deeper engagement with the Divine and that that communion might also be evident in the lives of those who constitute the liturgical assembly. In summary, our biggest task is to get the balance right between speech, music and silence. As to PA systems in our churches... there is no solution!

Liturgical Renewal: Presence

Colleen O'Reilly



Colleen O'Reilly is a life long Anglican and currently Vicar of St George's Anglican Parish of Malvern and a Canon of St Paul's Cathedral, in the Diocese of Melbourne. A graduate and Fellow of the Sydney College of Divinity, she completed doctoral studies in ritual and pastoral care at San Francisco Theological College in 1997.

This article is the text of a keynote address at the Hobart Conference, originally to be co-presented with Dr Margaret Smith who had to withdraw because of sickness.

INTRODUCTION

[The two presenters had agreed to discuss the spirituality of presiding as a form of presence, reflecting on their own experiences; so in the light of Sr Margaret's unavailability, Dr O'Reilly here reflects on her Anglican tradition. –Ed.]

I will discuss Anglican theologian Thomas Cranmer's position on the 'real presence' of Christ in the Eucharist and his liturgical expression of the prevailing, though contested belief of the English reformers in the sixteenth century. I will show that Anglicans continue to hold more than one view on this matter and that current revisions of Anglican liturgical texts continue to allow for diverging interpretations of the text.

Then I will move to consideration of the presider as a form of presence whose competence in the role is a key to people's experience of worship. I will also ask the question, 'does gender matter?'

To contextualise this reflection, I am a life long Anglican despite my Irish name. I grew up worshipping with the words and ethos the 1662 Book of Common Prayer in a Sydney suburban parish influenced by Tractarian theology and more modestly so by Anglo-Catholic ritual. Since 1995 I have been a priest in the Diocese of Melbourne and worked as the incumbent vicar in two parishes since late 1999. I am a member of General Synod and its Standing Committee, and also the Chaplain to that body which comprises Australian Anglicans of the widest possible theological divergence.

Liturgical renewal and Anglicans

Liturgical renewal in the Churches of the Anglican Communion is a matter for the local provincial, usually national, Church to decide through its Synods which compromise three houses: one of laity, one of clergy (including assistant bishops), and the diocesan bishop or in the case of a general (national Synod) a house of diocesan bishops.

This principle, that

every particular or national Church hath authority to ordain, change, and abolish, ceremonies or rites of the Church ordained only by man's (sic) authority, so that all things be done to edifying⁵⁸

is enshrined in the Thirty Nine Articles of Religion, a foundational document in Anglican polity. The recent story of Anglican liturgical renewal is one of converging influences, including the ripple effect of the Second Vatican Council and the desire to move from Cranmer's beautiful but increasingly obscure sixteenth century language to more contemporary idioms.

Anglicans have lost and gained much as a result. We have lost the cohesion of doctrine and prayer provided by having only one book for clergy and laity alike for daily worship. We have gained collections of liturgies with a unifying similarity and almost universally retained some gems of Anglican prayer, a greater variety of occasional offices (baptism, weddings, funerals and care of the sick and dying), and maintained the practice of using authorized rites. The reality on the ground is diverse. Anglicans of protestant persuasion tend to relegate the Holy Eucharist to an early hour and use minimal structure in the non-sacramental principal Sunday worship later in the morning. The mainstream of middle and more catholic persuasion retain the Eucharist as the primary Sunday worship. In one Australian diocese many parishes have almost abandoned traditional Anglican forms. Since this has eroded important principles of Anglican worship, attempts are being made by the diocesan bishop to retrieve the proper ordering of worship. The solution has been an unprecedented collection of liturgies authorized only in that diocese. Prayer book revision has been a movement 'from uniformity to family resemblance'⁵⁹ and no Anglican would now imagine uniformity of the kind The Book of Common Prayer provided for over three centuries is actually retrievable.

⁵⁸ Article XXXIV *Of the Traditions of the Church*. The overarching principle is that it is not necessary for traditions and ceremonies to be uniform in all places since 'for all times they have been divers... and may be changed according to the diversities of countries, times and men's (sic) manners' provided nothing be contrary to scripture.

⁵⁹ Charles Hefling & Cynthia Shattuck (Eds), *The Oxford Guide to the Book of Common Prayer. A Worldwide Survey*, Oxford University Press, 2006, pp. 230-67. Revisions of the 1662 Prayer Book have now so diversified in accordance with local context and theological positions that it is fair to say Anglican share common patterns rather than common prayers.

The recent story of Anglican liturgical renewal is one of converging influences, including the ripple effect of the Second Vatican Council.

In the Australian Church, the most frequently used rite for the Holy Eucharist is now the Second Order in *A Prayer Book for Australia* (APBA).⁶⁰ Hammered out in the Liturgical Commission of General Synod and slugged out, and altered, on the floor of General Synod in 1995, this is the form of Eucharist I am most familiar with as a presiding priest since my own ordination in that same year. This is the predominant rite I have in mind as I reflect on liturgical renewal through the lens of ‘presence’ although I do not exclude other sacramental and pastoral rites.

An explanatory note about Anglicans

Anglicanism and Anglican theologies most likely frustrates those used to succinct confessional documents or definitive statements of faith. We are a diverse and even untidy ecclesial community. It is both a limitation and our glory, in my view. In our present form we are largely the product of both ancient catholic tradition and protestant insights brought together in the politically charged sixteenth century, though constantly developed since. We are ‘clumsy and untidy’ and we baffle ‘neatness and logic’ as Archbishop Michael Ramsey wrote of us.⁶¹ Martyn Percy, principal of Ripon College, Cuddesdon describes us as a ‘commonwealth of belief and practice’ in which hard-fought struggle is usually an eventual convergence.⁶²

At its best this is a genius for comprehensiveness; at its worst it can be caricatured as so tolerant of any theological position that the wonderfully fictitious Sir Humphrey Appleby can inform Prime Minister Jim Hacker that ‘the Queen is inseparable from the Church of England and God is what is called an optional extra.’⁶³

‘Presence’ in the liturgy. How ‘real’ is it for Anglicans?

According to the Constitution on the Sacred Liturgy five modes of Christ’s presence in the liturgical celebrations of the Church are listed. These five modes are helpfully discussed in a recent paper by Gerald O’Collins SJ in the *Irish Theological Quarterly*⁶⁴. Using his own translation of the Vatican document, O’Collins describes these five modes of presence as,

⁶⁰ *A Prayer Book for Australia*, Broughton Books, 1995, pp. 119-65. The full title on the frontispiece reads, *A Prayer Book for Australia for use together with The Book of Common Prayer (1662) and An Australian Prayer Book (1978) Liturgical Resources authorised by the General Synod*. Following vigorous, sometimes very heated debate, over the detailed content of the new book in which members of the Diocese of Sydney frequently, and crucially successfully opposed the Liturgical Commission’s work, the book was subsequently rejected in Sydney.

⁶¹ Michael Ramsay, *The Gospel and the Catholic Church*, SPCK, London, 1990, 220 (first published 1936).

⁶² G R Evans and Martyn Percy *Managing the Church? Order and Organization in a Secular Age*, Sheffield Academic Press, Sheffield, 2000, 187.

⁶³ Yes, *Prime Minister*, ‘Bishops’ Gambit’ 1986.

⁶⁴ Gerald O’Collins SJ, Vatican II on the Liturgical Presence of Christ, *Irish Theological Quarterly* 2012, 77:3 pp. 3-17. <http://www.sagepublications.com>

first, Christ is present in the person of the minister; second, 'under the Eucharistic species'; third, in the celebration of all the sacraments (e.g. baptism); fourth, 'in his word'; fifth, in the assembled community 'when the Church prays and sings psalms'... together.⁶⁵

Later in his discussion of the presence of Christ in the sacraments, O'Collins quotes Karl Rahner SJ offering a warning about presence, namely, that 'presence does not admit to any strict or precise definition.'⁶⁶ Nevertheless, theologians have attempted precise definitions and Christians have fought and divided over what presence 'under the Eucharistic species means.'

Anglicans hear a position in Rahner's caution that we are well disposed to accept, in contrast to definitions of presence which appear to claim too much for one or other philosophical framework asserting that it explains all. I will return to O'Collins' writing on presence later, but first I want to explore why Rahner's statement appeals to Anglican sensibilities when it might seem weak or even 'woolly' to some.

At the time of the sixteenth century reform of English worship, Thomas Cranmer, Archbishop of Canterbury and chief compiler of the new liturgies of 1549 and 1552, was immersed in debate about the nature of the presence of Christ in the sacrament of holy communion. It was a major concern of the times, and a preoccupation for many years. Cranmer was influenced in his theology by two continental reformers, Ulrich Zwingli of Zürich, and Martin Bucer (1491-1551) from Strasbourg who spent his last years at Cambridge where he wrote a critique of the 1549 Prayer Book. Having said that, the extent to which Cranmer knew his own mind and stood his ground on matters of theological principle should not be underestimated. Out of the milieu of debate, often bitter and polemical debate, Cranmer drafted a service of the Lord's Supper which was clearly shaped by his rejection of the inherited theology of the medieval 'mass' as the representation of the sacrifice of Calvary and the bread and wine as changed in substance and become the physical body and blood of Christ.

Cranmer sought to inculcate through the liturgy the new thinking that Christ's presence was perceived in the minds of believers, who received the signs or tokens of Christ's earthly life, bread and wine, and fed on Christ in their hearts, by faith. He removed the rubrics telling the priest to hold the bread and wine at the words of institution, and placed the prayer offering the bread and wine after the communion of the people. As a further severing of the connection between bread, wine and real presence, Cranmer removed from the words of administration 'the body of Christ' and 'the blood of Christ' though retained them in the Prayer of Humble Access as we shall observe later.

⁶⁵ O'Collins, 3.

⁶⁶ O'Collins, 9.

Without actually wanting to state a definitive position, Anglicans can hold an authentic belief in the real presence and not feel compelled to say a great deal about it.

At the same time, in the Articles of Religion, Cranmer drew on words from Lutheran theology in the Augsburg Confession of 1530 to affirm that the bread and wine are *effective* signs. He was no mere memorialist.

Sacraments ordained of Christ be not only badges or tokens of Christian men's profession, but rather they be certain sure witnesses, and effectual signs of grace, and God's good will towards us, by the which he doth work invisibly in us, and doth not only quicken, but also strengthen and confirm our Faith in him.⁶⁷

Here in lies the ambiguity of theological position that has enriched and impoverished Anglicans ever since. Without actually wanting to state a definitive position, Anglicans can hold an authentic belief in the real presence and not feel compelled to say a great deal about it. Cranmer's original drafting has been modified at key moments in Anglican history and some of what he removed is long restored. These days, a century after the Oxford Movement, it is common place to attend a celebration of the Eucharist which in ritual matters is remarkably similar to a post-Vatican II celebration of the Roman rite, yet which retains the hallmarks of Anglican untidiness, or, perhaps better, deliberate imprecision. In contrast to what looks to an outsider to be Roman Catholic homogeneity, it would also be possible to attend an Anglican celebration that resembled the worst of low church determination not to 'do' anything much except to exalt the preaching and certainly not to appear to value the sacrament equally to the word, and never more so.

Christ's presence in the Eucharist was a hot button issue of reformation times, and resurfaces readily whenever Anglicans of differing theological traditions meet. Despite the significant statement of agreement on the Eucharist, prayerfully, carefully and skillfully crafted by the Anglican –Roman Catholic International Commission, and adopted by the bishops in conference at Lambeth as *an* expression (*emphasis mine*) of our theology, we Anglicans continue to dispute amongst ourselves the nature of Christ's presence in sacramental form.

The Agreed Statement says,

Communion with Christ in the Eucharist presupposes his true presence, effectually signified by the bread and wine which, in this mystery, become his body and blood.⁶⁸

⁶⁷ Article XXV.

⁶⁸ ARCIC IV, The Anglican-Roman Catholic Agreed Statement on the Eucharist, 1971. The Anglican and Roman Catholic Churches began official ecumenical discussions in 1970 and quickly discovered that they hold the same doctrine of the Eucharist. In 1971 ARCIC [Anglican-Roman Catholic International Commission] issued a joint statement on the Blessed

Some Anglicans, those of an ultra reformed puritan, disposition, would deny the Lord's Supper to be anything more than what they believe to be a 'memorial', that is a mere calling to mind of a past event, namely Christ's death. References to Christ's resurrection do not share equal prominence with references to the cross. This view is often described by their opponents as a belief in 'the real absence.' Absence may be too pejorative a word to use of all who hold these views, although many who do take an extreme position would say 'nothing happens' (and might even say it at the time of consecration!) except that the believer, if genuinely penitent and trusting, partakes of a 'symbolic meal, originating from Jesus' Last Supper with his disciples'.⁶⁹

As always, if you want to know what Anglicans believe you must consult the liturgical texts. The old saying 'lex orandi, lex credendi'⁷⁰ is particularly true of Anglicans who use the 1662 BCP as the measure for subsequent revisions. How we do that is, of course, itself disputed! We are not a confessing Church, despite the attempts to make it so during the abolition of the monarchy and episcopacy and establishment of Oliver Cromwell's Commonwealth (1649-1660). Nor are Anglicans given to *ex cathedra* statements of doctrine by bishops, individuals, or even synods. Councils of the Church may, and have erred. Anglicans universally have almost no appetite for a revised catechism and individual theologians must earn what authority they gain by the persuasion of their arguments. Appeals by some Anglicans to a primary source of authority other than to the three-fold interaction of scripture, tradition and reason or experience usually isolate scripture and place it above all else, sometimes even the creeds. You will hear some Anglicans espouse 'sola scriptura' as a theological method but that was never a position taken by the English reformers. It continues to be a borrowing from the continental reformers when Anglicans do it today.

Anglican polity is one where the creeds are the pre-eminent statements of faith, and prayers books express that credal faith in word and sacrament. This is enshrined in the 1961 Constitution that established the Australian Church as independent of the Church of England.⁷¹ So, what was Cranmer's considered theology of Christ's presence

Sacrament. At the 1988 Lambeth Conference of the Primates, Archbishops, and diocesan Bishops of the Anglican Communion world-wide adopted this Agreed Statement as an official teaching on Anglican Eucharistic doctrine.

⁶⁹ footnote reads: *The word transubstantiation is commonly used in the Roman Catholic Church to indicate that God acting in the Eucharist effects a change in the inner reality of the elements. The term should be seen as affirming the fact of Christ's presence and of the mysterious and radical change which takes place. In contemporary Roman Catholic theology it is not understood as explaining how the change takes place.*

⁷⁰ *Common Prayer. Resources for gospel-shaped gatherings.* Archbishop of Sydney's Liturgical Panel 2011. Development Version, 39.

⁷¹ The full statement is *ut legem credendi lex statuat supplicandi*, translated as *let the law of prayer establish the law of belief*. It is generally attributed to Prosper of Aquitaine.

⁷² The constitution of The Anglican church of Australia, PART I CHAPTER I. - FUNDAMENTAL DECLARATIONS

¹ The Anglican Church of Australia, being a part of the One holy Catholic and Apostolic Church of Christ, holds the Christian Faith as professed by the Church of Christ from primitive times and in particular as set forth in the creeds known as the Nicene Creed and the Apostles' Creed.

² This Church receives all the canonical scriptures of the Old and New Testaments as being the ultimate rule and standard of faith given by inspiration of God and containing all things necessary for salvation.

³ This Church will ever obey the commands of Christ, teach his doctrine, administer his sacraments of holy Baptism and Holy

in holy communion? Not surprisingly, given that the questions of Christ's presence in the bread and wine of the Eucharist was arguably the most contentious issue of his times, Cranmer's thinking changed and developed in debate and dispute with others. Among what one commentator has called 'the wearisome bulk of polemic'⁷² it is possible to discern Cranmer's insistence that Christ is truly present while he denied transubstantiation as the means of that presence.

As I said earlier, if you want to know what Anglicans believe consult the liturgical texts, or better still worship with us as a participant observer. It is in our worship that we use language as sparingly as possible to create the widest interpretation possible. Cranmer's own composition, The Prayer of Humble Access and the words of administration of the bread and wine, as reshaped in the 1662 Book, are fine examples of this multivalent approach.

We do not presume to come to this thy Table, O merciful Lord, trusting in our own righteousness, but in thy manifold and great mercies. We are not worthy so much as to gather up the crumbs under thy Table. But thou art the same Lord, whose property is always to have mercy: Grant us therefore, gracious Lord, so to eat the flesh of thy dear Son Jesus Christ, and to drink his blood, that our sinful bodies may be made clean by his body, and our souls washed through his most precious blood, and that we may evermore dwell in him, and he in us. Amen.

Then shall the Minister first receive the Communion in both kinds himself, and then proceed to deliver the same to the Bishops, Priests, and Deacons in like manner, (if any be present;) and, after that to the People also in order, into their hands, all meekly kneeling, and, when he delivereth the Bread to any one, he shall say,

The Body of our Lord Jesus Christ, which was given for thee, preserve thy body and soul unto everlasting life: Take and eat this in remembrance that Christ died for thee, and feed on him in thy heart by faith, with thanksgiving.

And the Minister that delivereth the Cup shall say,

The blood of our Lord Jesus Christ, which was shed for thee, preserve thy body and soul unto everlasting life: Drink this in remembrance that Christ's blood was shed for thee, and be thankful.

In 1995, following the earlier revisions of 1978 which passed in General Synod with much less difficulty, Australian Anglicans were given the following typical wording; these from the Preface to Thanksgiving One in the Second Order Eucharist referred to earlier⁷³.

Communion, follow and uphold his discipline and preserve the three orders of bishops, priests and deacons in the sacred ministry and deacons in the sacred ministry.

⁷² Gordon P. Jeanes, Signs of God's Promise. *Thomas Cranmer's sacramental Theology and the Book of Common Prayer*. London, T & T Clark, 2008, p. 140

⁷³ APBA, (1995), p. 128.

Merciful God, we thank you
for these gifts of your creation,
this bread and wine,
and we pray that by your Word and Holy Spirit,
we who eat and drink them
may be partakers of Christ's body and blood.

Presence and presiding

Shortly after being ordained, while watching an evening news item about a prominent cleric, I saw him greet the congregation without looking up. I assume it was an unconscious habit, and I resolved not to develop it myself. Being personally, and intentionally present to the congregation, and conveying that presence through gesture, voice and eye contact is primary to the task of leading worship. 'Strong, loving and wise' are the adjectives Robert W. Hovda chose to describe the desirable qualities of clergy 'dealing with and in the symbolic language...of liturgy.' Hovda's very influential book of the same name is concerned 'with a spirit, a consciousness, an awareness' in the one presiding at the ordinary Sunday gatherings of local congregations and from a variety of ecclesial traditions.⁷⁴ The capacity of presiding ministers to be 'present' to God, to the gathered congregation and to themselves is an essential element in the renewal of worship through presence.

I once heard a senior protestant lay woman quip, 'What is it that ministers do with sacraments? Oh, yes. Celebrate? Is that what they call it? It doesn't always look like it!'⁷⁵ If the presiding priest is not engaged in 'the careful, joyful work within the liturgy'⁷⁶ to use William Seth Adam's phrase, then how well will the rest of the congregation become present to the crucified and risen Christ who promises to be in the midst of even two or three who gather in his name?⁷⁷

The Donatists are wrong theologically, and pragmatically correct pastorally. This is especially true in Anglican culture.⁷⁸ People expect their vicar to know them, and to be known by the clergy of the parish. A priest received from Rome once said in a clergy conference in Melbourne that 'Anglicans are high maintenance'. A personal relationship with clergy may well be the catalyst without which many will not trouble

⁷⁴ Robert W. Hovda, *Strong, Loving and Wise. Presiding at the Liturgy*, The Liturgical Press, Collegeville, Minnesota, 1976, 1.

⁷⁵ Miss Freda Whitlam, speaking in a panel discussion at the first National Church Women's Conference, Coogee Bay Hotel, Sydney, 1974, organised by the NSW Ecumenical Council of Churches Commission on the Status of Women. Personal recollection.

⁷⁶ William Seth Adams, *Shaped by Images. One who Presides*, Church Hymnal Corporation, New York, 1995, 5.

⁷⁷ 'Where two or three are gathered together in my name, I am there in the midst of them.' Matthew 18.20

⁷⁸ Donatism: a fourth century dispute in which a schismatic group refused to accept that the efficacy of sacraments depended on Christ alone, and asserted that the unworthiness of the minister hindered the mediation of grace. The Donatist view did not gain acceptance and the Church has held since then that the mediation of grace is not dependent upon the state of grace of the minister. Anglicans express this in Article XXVI *Of the Unworthiness of the minister, which hinders not the effect of the Sacrament*.

to explore a deeper relationship with God. Liturgy which leads participants to glimpse new possibilities through the ‘performance’ of the presider has transformative potential in those willing to open themselves to the Spirit’s work.

The spirituality of the presiding ministers, the source of their capacity to be ‘present’, is fundamental to enabling the liturgy in all its elements to renew the faith of the community week by week. Primary responsibility for this rests with the presiding priest who must model the standard of ‘performance’ they expect in others who read, intercede, serve or administer the chalice.

I do not mean uniformity of style but rather a consistency of interior intention. However, style is important. Good style is, as Robert Hovda says is ‘appropriate, honest, authentic, as real and genuine as it can be.’⁷⁹ In addition, the presider needs an informed understanding of the rites and their role in leading. It is about taking the task with enough seriousness to be willing to learn, adapt, receive critique and above all, accept that they serve the liturgy and the assembly while at the same time being the one element or ‘personal thread’⁸⁰ to use Hovda’s image, which holds all together.

This is where a level of personal and spiritual maturity best enables presence. It requires an ability to grasp the paradox of being both the lynch pin and yet unobtrusive *at the same time*. I often say to members of the sanctuary party that the only mistake is to project one’s own ego in to the gathering; all the rest of what happens amiss is a glitch we deal with at the time. So, it is a serious mistake to project ‘look at me.’ It is glitch if a server is tardy bringing the alms basin to those waiting to hand up the collection.

One liturgist has expressed it this way,

What can we say of a spirituality of presiding at the Liturgy of the Eucharist? I would suggest three key ingredients: prayerfulness, intentionality and transparency. First and most important, presiders need to be prayerful. This begins in contemplation long before they reach the sacristy to prepare for the liturgy, and it continues as they stand at the altar with arms outstretched. In other words, if those who stand at the table proclaiming the Eucharistic prayer do not have a personal daily rhythm of prayer or meditation during the week, such prayerfulness will not magically happen when they stand before the assembly on Sunday morning.

Second, presiders need to be intentional about what they are doing. This means careful and reverent gestures that are not rushed or distracting. Whether bowing,

⁷⁹ Hovda, 63.

⁸⁰ Hovda, 68.

incensing the altar, inviting the assembly into the Eucharistic prayer with the words “Lift up your hearts” or distributing Communion to those who come before them, presiders need to be fully engaged in the process. Third, when presiders are prayerful and intentional, they will preside with transparency.

In short, presiding at the Liturgy of the Eucharist is not about the presider. It is about the service of God’s reign that we celebrate and remember with holy food and drink. So the more a presider can stay out of the way and not draw attention to himself (sic) the better. In the end, effective presiding at the Liturgy of the Eucharist should draw the whole community into that vision of the mystery of God that is both present among us and not yet fully revealed.⁸¹

Does gender matter?

Does gender matter? Is it different when the presider is a woman? My own experience has taught me that it is powerfully important that women as well as men enact symbolic roles in liturgy. Anglicans have by and large come to believe that this is best achieved by ordaining women to all three orders of ministry. In late 2012 we celebrated the twentieth anniversary of women priests. Now, almost 20% of Australian Anglican clergy are women. In addition, there are three (assistant) bishops and one bishop-elect who are women. It will be even more significant when a diocese elects a woman to be their ordinary.

The gender of those who lead and preside is a message in itself although that will be largely an unconscious message until a new awareness announces itself. Margaret Marsh was the first woman priest I ever met, in 1981. She came to live in Sydney with her family, from New Zealand where women were first ordained in 1977. She was not licensed in Sydney; such hospitality as such reciprocal recognition is called, was not on offer to a woman. I went to hear Margaret Marsh preach in St James’ King Street. There was never any hope of her presiding at the Eucharist that day but she was given permission to preach. Later she did preside at a Eucharist, around my coffee table. That morning, in one of Sydney’s oldest parish churches I watched as the Revd Margaret Marsh, vested as a priest walked in procession to the sanctuary. It was exciting; it was amazing; but suddenly my eyes were full of tears, tears not of joy but of grief. For the first time in all the years of church going since I was baptised at six weeks and went to Sunday school at three and had watched the processions of men, I knew without doubt what negative and false notions of myself as a girl child and then a young woman those processions had taught me. As I watched my first ordained woman it suddenly came to me that, ‘it really is OK to be a woman; being a woman really does have something to do with God after all.’

⁸¹ <http://americamagazine.org/issue/477/article/presiding-liturgy-eucharist> Keith F. Pecklers, S.J., is professor of liturgy at the Pontifical Gregorian University in Rome and professor of liturgical history at the Pontifical Liturgical Institute of San Anselmo.

It can be argued that the gender and the personality of the presider matter since, as O'Collins stresses, presence is relational. Just as Christ's presence in the sacraments is relational, or as O'Collins puts it, a 'presence to us,' so is the person standing before us a presence for us in worship. At this human level everything about that person makes a difference to our encounter with them and with God. The Holy Spirit will move between priest and people to mediate Christ's presence and can be said to be actualised and effective, but human factors can aid or block the Spirit's work as we well know from experience, even if we are reluctant to admit it. And given that in the incarnation, the Spirit takes bodily form why would we not expect bodily presence to be of importance.

In his paper already referred to, O'Collins lists 'feminine' as one of the ten characteristics of presence.⁸² As he notes, our first human experience of presence is maternal. In a lengthier discussion of the feminine in presence, O'Collins points out those ways in which Jesus' own behaviour exhibited feminine characteristics and the well established traditions in Christian spirituality of referring to God in maternal and feminine imagery.⁸³

On the other hand, the gender of the presider is of no account, nor should it be. Here the refutation of the Donatist position is spot on. All are unworthy, but not on account of gender which some ecclesial traditions continue to use as an impediment to ordination or full authorisation for ministry.

Donatism is however rampant. It is clear that many people choose a parish or worshipping assembly in significant part on account of the clergy. Theologically this is deplorable. Pastorally, it is understandable. In the end the key resource anyone brings to presiding or pastoral care is themselves; the person they are, with voice, gestures, formation and knowledge and particular attitudes and principles, all brought to bear on the role they are exercising in relationship with others. It is the presider's responsibility through their own relationship with God and the Church to be and become the most effective and fruitful they may be *while at the same time* accepting that it is the Spirit's work, and not theirs, when the presence of the living Christ is experienced. Christ has no other means of renewal now than we – worshippers and leaders - who are willing to serve the Spirit's purposes.

⁸² O'Collins, 15.

⁸³ Gerald O'Collins, SJ, *Christology. A Biblical, Historical, and Systematic Study of Jesus*. Oxford University Press, Oxford (2nd ed. 2009), 354 ff.

The liturgical consummation of space

Stephen Hackett



Dr Stephen Hackett is a priest of the Missionaries of the Sacred Heart, currently serving as a pastor of St Thomas the Apostle Parish in the Archdiocese of Brisbane. He is chairman of the National Liturgical Architecture and Art Board and a member of the National Liturgical Council, advisory bodies to the Bishops Commission for Liturgy of the Australian Catholic Bishops Conference. His primary fields of research and consultancy are the architecture of liturgy and the liturgical arts.

The architectural making of space

In the treatise or five books *On Consideration*, addressed to Pope Eugene III (r. 1145–1153) by Saint Bernard of Clairvaux (1090–1153), the latter asks the question, ‘What is God?’, and answers, ‘He [God] is length, width, height and depth.’⁸⁴ St Bernard acknowledges that this answer describes God according to our mode of conceiving of God, not according to God’s own nature; he then proceeds to expound on God in terms of length, width, height and depth.⁸⁵ We use these same attributes by which Saint Bernard of Clairvaux designates God to define and describe and measure space.

When architecture applies these attributes to the making of space, its primary principle is the point.⁸⁶ Length and width, height and depth proceed from the point, which cannot be seen and which has no spatial extension in and of itself. The point therefore transcends the finite and symbolises the Infinite, one of the names appropriated for God.⁸⁷ All geometry derives from the point, which we represent with a dot (Figure 1).

⁸⁴ Bernard of Clairvaux, *Treatise on Consideration*, tr. a priest of Mount Mellerey, Dublin: Browne and Nolan, 1921, 190. See Ephesians 3:18.

⁸⁵ *Ibid.*, 190–194.

⁸⁶ Paul Walsh & Harry Stephens, ‘The Cathedral: Its Origins, Its Design Principles and Their Application’, in *The Cathedral: A Living Church at the Heart of the Diocese, Proceedings of a Colloquium*, Darwin: Catholic Diocese of Darwin, 2010, 6.

⁸⁷ *Ibid.*, 20, endnote 9.

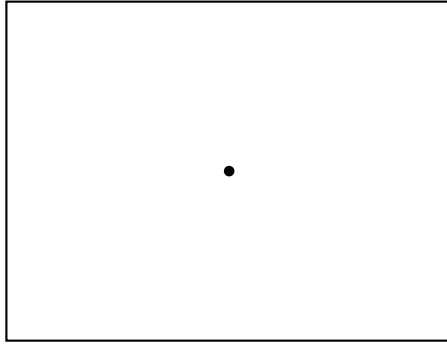

Figure 1: The point, primary principle of architecture, represented as a dot.

In turn, the dot is visibly enlarged to form a circle, the least differentiated geometric form and an expression of Oneness and Unity, another symbol of God⁸⁸ (Figure 2).

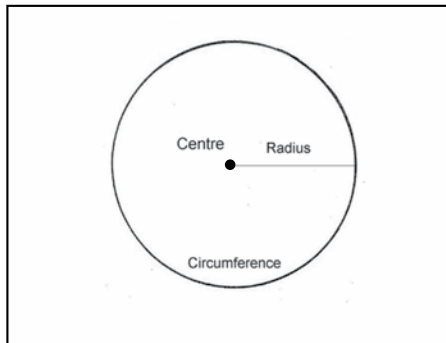

Figure 2: The circle, visible enlargement of the dot, showing radius and circumference. (Harry Stephens⁸⁹)

Unity creates by dividing itself: a circle's circumference marked off by the measure of its radius two-dimensionally yields a hexagon; connecting the hexagon's points three-dimensionally reveals a square, cubed; and this in turn manifests length, width, height and depth, that is, the directions of the cosmic order, variously north, south, east, west, zenith and nadir, or with reference to human persons bodily in space, front, back, left, right, up and down⁹⁰ (Figure 3).

⁸⁸ Robert Lawlor, *Sacred Geometry: Philosophy and Practice*, London: Thames and Hudson, 1982, 12, 16.

⁸⁹ Walsh & Stephens, 'The Cathedral', 7.

⁹⁰ *Ibid.*, 7-8.

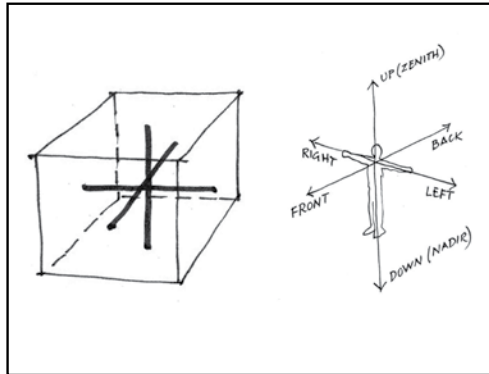

Figure 3: The directions of the cosmic order, as derived from the circle, and as represented with reference to the human body. (Harry Stephens⁹¹)

A rich tradition of sacred geometry derives from these foundations and constitutes the origins of architectural archetypes. In the history of church design we can readily identify the influence of this tradition and these archetypes: in Romanesque Cistercian churches where plan and ratios were informed by musical consonances; in Gothic churches where the vesica-pisces and the figure of the universal Christ-Man determined both structural geometry and layout; and, of course, in the relationships of classical proportions and orders in Renaissance churches.⁹² In every instance the design of churches in these architectural epochs comprises a synthesis of geometry, cosmology, material, polity, creed, theology, ecclesiology and liturgy.

If this seems altogether too esoteric, perhaps this conceptual construction of space can be grounded in a more accessible scriptural exposition of space. In the Book of Genesis (28: 10–22), as part of the Jacob saga, we read:

Jacob left Beer-sheba and went towards Haran. He came to a certain place and stayed there for the night, because the sun had set. Taking one of the stones of the place, he put it under his head and lay down in that place. And he dreamed that there was a ladder set up on the earth, the top of it reaching to heaven; and the angels of God were ascending and descending on it. And the Lord stood beside him and said, “I am the Lord, the God of Abraham your father and the God of Isaac; the land on which you lie I will give to you and to your offspring; and your offspring shall be like the dust of the earth, and you shall spread abroad to the west and to the east and to the north and to the south; and all the families of the earth shall be blessed in you and in your offspring. Know that I am with you and will

⁹¹ Ibid., 8.

⁹² Thomas Barrie, *The Sacred In-Between: the Mediating Roles of Architecture*, London: Routledge, 2010, 142–150; and Lawlor, *Sacred Geometry*, 92.

A rich tradition of sacred geometry derives from these foundations and constitutes the origins of architectural archetypes.

keep you wherever you go, and will bring you back to this land; for I will not leave you until I have done what I have promised you.” Then Jacob woke from his sleep and said, “Surely the Lord is in this place – and I did not know it!” And he was afraid, and said, “How awesome is this place! This is none other than the house of God, and this is the gate of heaven.”

So Jacob rose early in the morning, and he took the stone that he had put under his head and set it up for a pillar and poured oil on the top of it. He called that place Bethel; but the name of the city was Luz at the first. Then Jacob made a vow, saying, “If God will be with me, and will keep me in this way that I go, and will give me bread to eat and clothing to wear, so that I come again to my father’s house in peace, then the Lord shall be my God, and this stone, which I have set up for a pillar, shall be God’s house ...”⁹³

Here is the primary principle of the architectural making of space – the point – signified by the stone that Jacob had put under his head to sleep and upon waking set up as a pillar. Here is the vertical – zenith and nadir, up and down – signified in Jacob’s dream by the ladder set up on the earth and reaching to heaven, with the angels of God ascending and descending on it. And here is the horizontal – the cardinal directions, front and back, left and right – in the promise of God to Jacob as he dreams: ‘you shall spread abroad to the west and to the east and to the north and to the south ...’. Here in the Book of Genesis are found length, width, height and depth. Here space is fashioned for worship as Jacob sets up as a pillar the stone that signifies his encounter with God at that place, ritually anoints this pillar, and names it as God’s house.

The interplay of space and liturgy in the design of the buildings we call churches, cathedrals, chapels, oratories, sanctuaries and shrines stems from the point as the primary principle of geometry and finds built material form that is defined by length, width, height and depth, and from the transformation effected by Christ’s presence through ‘grace, faith, and sacrament’⁹⁴ in the enactment of liturgical rites. Indeed, a study of the relationship between space and liturgy in the evolution of church architecture reveals the liturgy as the foremost and enduring influence in the spatial arrangement of these buildings.⁹⁵

⁹³ NRSV

⁹⁴ Aidan Kavanagh, *Elements of Rite: A Handbook of Liturgical Style*, New York: Pueblo Publishing Company, 1982, 15.

⁹⁵ Stephen Hackett, ‘The Architecture of Liturgy: Liturgical Ordering in Church Design; the Australian Experience in Perspective’, PhD thesis, The University of New South Wales, Sydney, 2011, 85–87.

The reciprocity of liturgy and space

In discussing the relationship between space and liturgy, it has become almost normative to consider this relationship in terms of the influence of architecture on liturgy: ‘what does architecture do to liturgy?’ This is a valid and necessary question that warrants ongoing discussion. In contrast, the inverse question as to the influence of liturgy on architecture remains largely unasked: ‘what does liturgy do to architecture?’ Perhaps much of the disquiet about church architecture since the mid twentieth century exists at least in part because the influence of liturgy on architecture has not much featured in the discourse about the design of liturgical space, and so remains under-appreciated. In establishing some points of reference for reviewing liturgical renewal from the perspective of the spaces in which liturgy is celebrated, both of these questions will be addressed. First, ‘what does architecture do to liturgy?’ and then, ‘what does liturgy do to architecture?’

What does architecture do to liturgy?

The first and relatively familiar question as to the influence of architecture on liturgy can be viewed from at least three related standpoints: first, the influence of architecture upon persons, places and relationships within a church; second, the influence of architecture upon the enactment of liturgical rites; and third, the influence of architecture in shaping the strategic symbolism inherent in liturgical space. The substance of the first standpoint was well summarised by Mark Searle some thirty years ago, when he observed that,

No church building is ecclesologically innocent: it expresses – and forever thereafter impresses – a sense of what it means to belong to the church, the respective roles of different ministries, the wealth or poverty of the Christian imagination, the sense of where Christ is to be found and so on. It is more than a sermon in stone: it is a multimedia communication of a version of the Christian gospel, communicated in the shape of the building, its interior arrangements, its decoration and appointments, the kind of interaction it fosters or prohibits among the worshippers. Everything speaks, everything tells us who we are (for better or worse) and what our place is.⁹⁶

Here Searle identifies the ways in which architecture informs the ecclesial identity of those who comprise the worshipping assembly – including its ministers – in terms of how the ordering of liturgical space reflects the ordering of the Church community, the varying roles and exercise of authority among the members, and the participation of all or just some in the liturgy. Further, Searle draws attention to the extent to

⁹⁶ Mark Searle, ‘Church Building’, *Assembly*, 10:2 (1983), 225.

which the church building, its layout and furnishings, and its iconographic program all contribute to the worshipping assembly's self-understanding, life and mission. William Seth Adams echoes Searle's observations in noting that '... liturgical spaces are powerful teachers. They teach the church about the church, about who we are, how we work, what we do, what is important to us, who is important to us; and they teach us about God.'⁹⁷

The second standpoint, concerning the influence of architecture upon the enactment of liturgical rites, is multifaceted. Peter Williams describes the importance of imagining liturgical space for every rite that is to be celebrated therein, so as to 'appreciate how movement and gesture, ceremonial and symbol might inform the worshipper and the ministers in their respective roles.'⁹⁸

William Seth Adams adopts a two-tiered functional approach, identifying first what is done in liturgical space and, in light of this, what the space means. 'In our liturgical space,' Adams observes, 'we gather, stand, kneel, sit, see, are seen, read, sing, speak, listen, play music, are silent, touch, move, eat, wash, promise, bless, commend, heal, anoint and lay hands on people ... the spatial order must be directed and shaped by what we do.'⁹⁹ 'What we do' leads into 'the second piece of functional work a liturgical space has to do. It has to "mean" something.'¹⁰⁰ Accordingly, Adams elaborates four theological categories – God, the church, the sacraments and creation – which he believes ought to inform deliberation of the meaning of liturgical space.¹⁰¹

Another approach has been outlined by Tom Elich, who advocates setting aside the notion of churches having a front and back, so as to be free to design liturgical space in accordance with established liturgical relationships.¹⁰² These would include, for example, the relationships between the places for entry, for the assembly or congregation, for altar, ambo and chair of liturgical presidency or leadership, and for the baptismal font.

Each of these approaches is informed by the rubrics and other ceremonial instructions given in the liturgical books – such as the *Roman Missal*, *Uniting in Worship*, *A Prayer Book for Australia*, *Church Rites* and the *Euchologion* – and by the principles, customs and norms of liturgical architecture as set forth in directories and guidelines for church design. From these same sources derive six distinct yet related liturgical spaces which together constitute the spatial setting for worship. These are

⁹⁷ William Seth Adams, *Moving the Furniture: Liturgical Theory, Practice, and Environment*, New York: Church Publishing Incorporated, 1999, 150.

⁹⁸ Peter Williams, 'St Patrick's Cathedral, Parramatta: the Proof of the Pudding is in the Eating,' in *The Cathedral: A Living Church at the Heart of the Diocese, Proceedings of a Colloquium*, Darwin: Catholic Diocese of Darwin, 2010, 75-76.

⁹⁹ Adams, *Moving the Furniture*, 141.

¹⁰⁰ *Ibid.*, 142.

¹⁰¹ *Ibid.*, 142-150.

¹⁰² Tom Elich, 'Churches Back to Front,' *Liturgy News*, 35:3, (2005), 10-11.

entry space, processional space, ritual space, assembly or congregation space, music ministry space, and sanctuary space. Elaborating briefly on each of these spaces:

Entry space may be a portal or transitional space that serves as a threshold between secular and worship spaces. Or it may be a sequence of arrival, portal, gathering, hospitality and transitional spaces. Single or sequenced, entry space should accommodate liturgical welcoming and introductory rites as well as processional movement into the church and from it.

Processional space serves as a 'ceremonial path' connecting the entry space and the altar.¹⁰³ Processional space should provide for gracious ceremonial movement which avoids congestion of ministers through entry and ritual spaces and upon arrival in the sanctuary.

Ritual space provides for the action by the whole assembly, for example in the ministering of communion. It accommodates rites of sending out, such as the dismissal of catechumens and the departure of children to celebrate their own liturgy of the Word. It is a locus for liturgical-sacramental enactment to which members of the assembly are called forth during such rites as Christian initiation, marriage, and funerals. Ritual space should therefore be at or near the liturgical centre of the church yet 'not create a chasm between the assembly and the altar and/or ambo'.¹⁰⁴ Being intended for both communal and individual participation at significant moments of life, ritual space is described by architects Robert Habiger as the 'place of intimacy' and Randall Lindstrom as a 'place of honour'.¹⁰⁵

Assembly or congregation space facilitates the active participation of the worshipping assembly in liturgical celebration. It should give the assembly a sense of being gathered together and, in some ecclesial communities, of being gathered to the altar, so as to engage corporately in enacting the liturgical rites. The ordering of assembly or congregation space should foster the unity of worshippers and ministers, while simultaneously reflecting the hierarchical ordering of the liturgy and of the Church.

Music ministry space is closely related to assembly or congregation space and is ordinarily designed more to foster the participation of worshippers in the liturgy than for choral or solo performance of liturgical music. It needs to be designed with ample room for singers, musicians, and instruments. It also needs to adequately provide for the projection of vocal and instrumental sounds, either by excellent natural acoustic properties or by electronic means of amplification.

Sanctuary space is the primary focus of liturgical enactment. Depending on ecclesial

¹⁰³ Robert D. Habiger, 'Appropriate Space for Weddings and Funerals,' *Environment and Art Letter*, 8:1, (1995), 5.

¹⁰⁴ *Ibid.*, p. 6.

¹⁰⁵ Habiger, 'Appropriate Space for Weddings and Funerals,' 6; Randall Lindstrom, interview with author, 4 August 2008.

Designing space for liturgy is always much more than an act of arranging the furniture for liturgical celebration.

liturgical traditions, it is centred on the altar, ambo or font, in relation to which are placed the other significant liturgical furnishings, including the seat or chair of liturgical presidency or leadership and, in some Churches, the place for the reserved sacrament. The sanctuary – or a clearly related nearby space – needs to accommodate all who exercise liturgical ministry there, ordained and lay. Sanctuary space should provide for ease of processional and other ceremonial movement. Unimpeded sightlines and ease of access from assembly and music ministry spaces are desirable.

The third standpoint regarding the influence of architecture on liturgy concerns the strategic symbolism inherent in liturgical space, which is to say that designing space for liturgy is always much more than an act of arranging the furniture for liturgical celebration. As already noted with regard to the approaches outlined by Peter Williams and Tom Elich, the design of liturgical space conveys both symbolism and relationship, and the confluence of these two elements. As David Torevell observes:

The use of symbolic space and positionings also fulfil a vital function in liturgy and are never only for the ease of congregational participation ... Primarily strategic, they add to the creative, mnemonic and symbolic dynamics which unfold during every celebration. ... Each item or 'thing' within the space is held in symbolic harmony by the relationship between the different items, some of which are stationary and some of which move according to the liturgical season. But it is the positioning of one to the other, in appropriate arrangement which constitutes the 'informed' symbolic space.¹⁰⁶

This becomes evident, for example, in the multivalent meaning of the baptismal font. A fixed and stationary font speaks of the perennial value of baptism and incarnates it as a vital foundation of Christian life; whereas a moveable font risks neutering the symbolic power of the sacrament and diminishing its significance.¹⁰⁷ Placed in a baptistery separate from the church, the font highlights the significance of this primary sacrament of initiation. Placed at the entrance to a church, the font emphasises admission into the community of faith. Placed in the midst of the assembly or congregation, the font signifies the common priesthood of all the baptised. Placed in or near the sanctuary, the proximity of font and altar may reinforce that what begins in baptism is nourished in Eucharist; or it may distort the meaning of baptism by implying an overly clerical character. By its design the baptismal font

¹⁰⁶ David Torevell, *Losing the Sacred: Ritual, Modernity and Liturgical Reform*, Edinburgh: T & T Clark, 2000, 177.

¹⁰⁷ Kavanagh, *Elements of Rite*, 17.

can symbolise cleansing and purification, the womb of rebirth, participation in Christ's triumph over the grave, or dying with Christ so as to rise with him.

The celebration of baptism by infusion (pouring) tends to convey its sacramental symbolism less powerfully than celebration by immersion, just as an ample font of flowing water will better signify the water of baptism as 'living' than will a small font of still water. Moreover, the font may, by virtue of its place, design and related iconography, evoke drinking of the living water that flowed from Jesus' pierced side, incorporation into Christ, transformation by the Trinity, and initiation into the Christian community.

These three standpoints concerning the influence of architecture upon liturgy, even if not always articulated in this way, are nevertheless readily found in the current literature. They are typical of contemporary responses to the question, 'what does architecture do to liturgy?' In contrast, relatively little has been said about the influence or effect of the liturgy upon church architecture; in fact the question, 'what does liturgy do to architecture?' has rarely been asked. Yet perhaps if it had been, the architectonic quality of church design and iconographic programs in the current era might have been better aligned with liturgical enactment and drawn less criticism.

What does liturgy do to architecture?

In speaking of the influence or effect of liturgy upon architecture, the emphasis is not on rites for the consecration, dedication or blessing of a church building, but on the liturgical act. This is not to understate the importance and validity of dedicatory rites; from the earliest times the Christian tradition has understood that 'a building becomes a church not because of its architecture but through consecration.'¹⁰⁸ Indeed, by rites of consecration or dedication a church building is definitively set apart for the liturgy.¹⁰⁹ Rather, in emphasising the liturgical act – understood in terms of the three essential elements of 'attention/contemplation, the integration of body and soul, and communality/participation'¹¹⁰ outlined by Romano Guardini – the 'length, width, height and depth' (to appropriate this phrase) of the liturgy in its manifold nature are acknowledged in all their potency.¹¹¹ More particularly, in focussing on the influence or effect of the liturgical act upon architecture, emphasis is given to letting 'the liturgy be itself – a transformative icon of the *ordo* of God.'¹¹²

¹⁰⁸ Josef Pieper, *In Search of the Sacred*, tr. Lothar Krauth, San Francisco: Ignatius Press, 1991, 97.

¹⁰⁹ *Ibid.*, p. 99.

¹¹⁰ Robert Barron, *Bridging the Great Divide: Musings of a Post-Liberal, post-Conservative Evangelical Catholic*, Lanham: Rowman & Littlefield Publishers, 2004, 54.

¹¹¹ Romano Guardini, 'The Cult act and the Present Task of Liturgical Education', 1964, posted as 'A Letter from Romano Guardini on the Essence of the Liturgical Act – 1964', www.jknirp.com/guard.htm, accessed 15 January 2013.

¹¹² Barron, *Bridging the Great Divide*, 66.

The transformative capacity inherent in the liturgy is foundational to understanding the influence or effect of the liturgy upon architecture. Two responses to the question ‘what does liturgy do to architecture?’ will be set forth, one deriving from the Eastern Church, the other from the Western Church. Before turning to these, however, it must be acknowledged that there exists another answer to ‘what does liturgy do to architecture?’, and that answer is ‘nothing’.

Such a response can be identified in the work of the influential architect Edward Anders Sovik, who in the 1970s advocated a return to what he called the ‘Non-Church’ akin to his perception of the liturgical setting of the early Church.¹¹³ Sovik argued that:

A house of worship is not a shelter for an altar; it is a shelter for people. It is not the table that makes a sacrament; it is the people and what they do. The things are adjuncts, conveniences, symbols, utensils. The presence of God is not assured by things or by symbols or by buildings, but by Christian people.

If this is so, and if we recognize the relative unimportance of things, and consciously try to keep this order of importance clear, the early Christian use of borrowed spaces and portable equipment and the attempt to achieve domestic rather than monumental character in architecture will not disturb but rather attract us.¹¹⁴

Sovik went on to outline a preference for liturgical spaces that are secular in character, impermanent, flexible and suited to multi-purpose use, devoid of cultic images and sacred furnishings, and thereby not explicitly associated with the liturgical act.¹¹⁵ Despite this conviction, he in fact designed a number of churches, including for Baptist, Methodist, Lutheran and Roman Catholic congregations.

The 1978 document of the Bishops’ Committee on the Liturgy (USA), *Environment and Art in Catholic Worship*, took a comparable stance, at least in part, though not as extreme as Sovik’s. *Environment and Art in Catholic Worship* stated that,

The norm for designing liturgical space is the assembly and its liturgies. The building or cover enclosing the architectural space is a shelter or “skin” for a liturgical action. It does not have to “look like” anything else, past or present.¹¹⁶

This emphasis on the primacy of the liturgical assembly and apparent rejection of the history of church design attracted the ire of critics who subscribed to a more

¹¹³ Edward A. Sovik, *Architecture for Worship*, Minneapolis: Augsburg Publishing House, 1973, 33, 37.

¹¹⁴ *Ibid.*, 33.

¹¹⁵ *Ibid.*, 37.

¹¹⁶ Bishops’ Committee on the Liturgy, *Environment and Art in Catholic Worship*, United States Catholic Conference, 1978, §42, 25.

sacral view of liturgical space and held to the existence of perennial values in the tradition of church architecture. Yet at the same time *Environment and Art in Catholic Worship* acknowledged that the liturgy in some way transformed the architecture of its setting. It identified the primary demands made by the liturgy upon space as being ‘the gathering of the faith community in a participatory and hospitable atmosphere for word and eucharist, for initiation and reconciliation, for prayer and praise and song’¹¹⁷; it then asserted that ‘such a space acquires a sacredness from the sacred action of the faith community which uses it.’¹¹⁸

The Russian-born theologian Paul Evdokimov (1901–1970) ascribed this acquisition of sacredness to a logic inherent in the sacramental mysteries, ‘that everything is destined for a liturgical fulfillment.’¹¹⁹ He applied this consecration through liturgical participation to created things, by which the things of the world are de-profaned and become ‘an epiphany of the sacred.’¹²⁰ This same consecration through liturgical participation can by extension be applied to space which has been made by architecture for the liturgical act.

Evdokimov explained the destiny of things in liturgical fulfilment in this way:

The final destiny of water is to participate in the mystery of the Epiphany; of wood, to become a cross; of the earth, to receive the body of the Lord during his rest on the great Sabbath; of rock, to become the “sealed Tomb” and the stone rolled away from in front of the myrrh-bearing women. Olive oil and water attain their fullness as conductor elements for grace on regenerated man. Wheat and wine achieve their ultimate *raison d'être* in the eucharistic chalice. Everything is referred to the Incarnation and everything finds its final goal and destiny in the Lord. The liturgy integrates the most elementary actions of life: drinking, eating, washing, speaking, acting, communing ... It restores to them their meaning and true destiny, that is, to be blocks in the cosmic temple of God’s glory.¹²¹

Throughout this exposition Evdokimov references the *ordo* of Orthodox liturgical praxis – the great feasts, prayers, customs, sacramental matter – to reveal how ‘a piece of being becomes a hierophany, an epiphany of the sacred.’¹²²

Now, there is an Eastern theology of the church building, endorsed and reiterated by Evdokimov that is articulated in terms of the symbolism of every architectural and iconographic element – geometry, axes and orientation; nave, iconostasis and sanctuary; doors, aisles and dome; ambo, altar and tabernacle; icons of the saints, image of the

¹¹⁷ Ibid., §40, 24.

¹¹⁸ Ibid., §41, 24.

¹¹⁹ Paul Evdokimov, *The Art of the Icon: a Theology of Beauty*, tr. Steven Bigham, Redondo Beach: Oakwood Publications, 1990, 117.

¹²⁰ Ibid.

¹²¹ Ibid.

¹²² Ibid.



Photo courtesy of Julie Moran

Working on the liturgical space – the Hobart Conference

mother of the Lord, and the cross. A Western theology of the church building has much in common with its Eastern counterpart, albeit with a number of architectural and artistic variations. The liturgical renewal, evident in church architecture from the 1920s, departed from such theology, not so much in rejection of it as supplanting it with recognition that the liturgy is the primary determinant of church design. A consequence of this has been to leave the renewal of church architecture ‘exposed’ – reduced to function alone, or aligned with the minimalism identified with architectural modernism, or subject to the polemical discourse of some commentators and writers, or disdained by architects who espouse historicism in the cause of good church design.

Mindful of this shift and its consequences, I wish to posit that Evdokimov’s notion of consecration through liturgical participation, his belief that everything is destined for liturgical fulfilment, be applied to architecture so that liturgical space comes to be seen as an epiphany of the sacred. Space, admittedly, is not a thing in the way wood and stone, water and oil, wheat and wine are things. Nevertheless it is put to liturgical use just as these things are: wood is cut and crafted to form a cross; olives are pressed to make oil for anointing; wheat is ground into flour in the baking of bread for eucharist. Liturgical space is similarly made by architecture and construction.

Just as wood and oil and wheat attain their fulfilment and destiny through human use in the liturgical act, might not architecture also attain its destiny, its fulfilment or perfection, through human use in the liturgical act? Might not the act of making space that we call 'building' be included together with Evdokimov's list of the most elementary actions of life – drinking, eating, washing, speaking, and so forth – which the liturgy integrates? The act of building takes longer and its outcome is generally more enduring than these other elementary actions of life, yet the making of space figures significantly among indispensable human activities. Augustin Ioan, in his study of sacred space, suggests that architecture might well be understood in this way. Indeed, he holds that 'construction does, as a matter of fact, take place in the realm in which epiphanies occur'.¹²³

Where Paul Evdokimov looked to the destiny of all things in liturgical fulfilment, such that pieces of being become epiphanies of the sacred, Hans van der Laan looked to the elevation of the humblest of human needs to attain pre-eminent value as liturgical signs.¹²⁴ Van der Laan was an architect and Benedictine monk, first of Oosterhout and later of Vaals, abbeys established in the liturgical tradition of Solesmes. He highlighted three fundamental human needs in particular, for which we are dependant on nature: food, clothing and shelter. Here he referenced the Book of Ecclesiasticus (29:21) and the wisdom of Jesus ben Sirach: 'The necessities of life are water, bread, and clothing, and also a house to assure privacy'.¹²⁵ These fundamental human needs are raised to their highest expression in liturgical usage: food is signified by the altar vessels; clothing is signified by the vestments; and the house is signified by the church building.¹²⁶

Human recognition of the need for food, clothing and shelter followed as a consequence of the Fall. Michel Remery explains Hans van der Laan's theoretical conception of the way in which liturgy elevates fundamental human needs to their highest purpose:

For his survival man makes buildings, vestments and vessels. These were for van der Laan the three fundamental fields of human 'making'. The forms man makes he called the forms of society or 'cultural forms'. The first function of these cultural forms is to protect and serve man. A further role is to express meaning. When these 'expressive forms' no longer have a functional role, but are only intended to convey an idea, Van der Laan spoke of 'monumental forms'. Man-made forms play their most eminent role in liturgy. The 'forms of liturgy' are at the same time functional, expressive and monumental. Every liturgical form is part of the complete liturgy, which is directed

¹²³ Augustine Ioan, *Sacred Space*, tr. Alina Ciric, Etna: Centre for Traditionalist Orthodox Studies, 2002, 28.

¹²⁴ Hans van der Laan, *The Play of Forms: Nature, Culture and Liturgy*, tr. Richard Padovan, Leiden: Brill, 2005, 78.

¹²⁵ NRSV.

¹²⁶ van der Laan, *The Play of Forms*, 76–77.

towards communication with God. It is in liturgy that a divinely instituted relation between matter and Mystery occurs.¹²⁷

Van der Laan regarded the liturgy as a whole as a sign. Consequently, the ordinary things of life that we use in liturgy 'reappear as signs intended for our communion with God.'¹²⁸ He observed that,

We rediscover in liturgy the entirety of words, gestures and objects that govern our daily life, but reduced to a few typical words, typical actions and typical objects. Houses, clothing and utensils, the paintings and books of ordinary life are represented by a single aula, a great hall that manifests the basic form of the human dwelling in all its purity [in the liturgical renewal of twentieth century church architecture van der Laan concluded that the early Christian basilica was the prototypical architectural expression; hence his reference to a single hall¹²⁹]; by a few vestments, but such as to bring to light the archetypal form of human clothing; by the basic types of utensil used at an ordinary meal, a dish for food and a cup for drink ...¹³⁰

Developing this theme, van der Laan further stated that,

Churches are human habitations, which are not used to live in, however, but to express dwelling with God. But in order to fulfil their liturgical function, which consists only in their being a sign, they must be exemplary types of human dwelling.¹³¹

For Hans van der Laan the highest goal of architecture, of the making of space, is attained in service of the liturgy through the dedication of buildings for use as churches. Architecture, and other things made by humankind, have a role in the work of sanctification, and fulfil this role within space and time, the two fundamental conditions of our material existence.¹³² 'By appointment and institution,' says van der Laan, 'pieces of space and time are set apart, within which things and signs hold their liturgical value.'¹³³ The liturgical value of architecture, as of vessels and vestments, is realised in their participation in the liturgical act where, by God's grace, they serve to express and foster communion between God and humanity.

¹²⁷ Michel Remery, *Mystery and Matter: On the Relationship between Liturgy and Architecture in the Thought of Dom Hans van der Laan OSB (1904-1991)*, Leiden: Brill, 2011, 476.

¹²⁸ van der Laan, *The Play of Forms*, 31.

¹²⁹ Caroline Voet & Yves Schoonjans, 'Dom Hans van der Laan's Architectonic Space as a Contemporary Interpretation of *Connaissance Poétique* within Sacred Architecture', *Il Congreso Internacional de Arquitectura Religiosa Contemporánea Entre el Concepto y la Identidad*, Ourense, 2009, 4, http://www.arquitecturareligiosa.es/historial_congresos/congreso01_2009/documentos/publicacion/54.pdf, accessed 17 January 2013.

¹³⁰ van der Laan, *The Play of Forms*, 31.

¹³¹ *Ibid.*, 32.

¹³² Michel Remery, 'The Influence of Solesmes on the Theory of Dom Hans van der Laan OSB on Liturgy and Architecture', *Jaarboek voor Liturgieonderzoek*, 26 (2010), 153; van der Laan, *The Play of Forms*, 33.

¹³³ van der Laan, *The Play of Forms*, 33.

Conclusion

Liturgical space, designed and constructed and given permanence in its built form, of course has an effect on the liturgy that is celebrated within. This is why it is vital that the liturgy be the foremost influence informing church architecture. The liturgy in turn, in all it signifies and effects of our communion with God in Christ, continually recreates space, elevating the building we call church to its highest order. It is not the architectonic quality of the church building, nor the value of its material construction, nor the reputation of its architect and artists – significant as each of these factors may be – but the liturgy which fulfils and perfects space. It is what a church is designed and built for, what is enacted within it, which brings architecture to its destiny in liturgical fulfilment, such that it becomes an epiphany of the sacred.

All space finds its destiny in God as, indeed, does all creation (Romans 8:22). The space we make with length, width, height and depth for the liturgical act – the space we call ‘church’ which is named for the community of the Church which gathers there to celebrate the liturgy – this space with its architectural form and program of iconography becomes a sign of the destiny of all space and of all who dwell in space.

The Ecumenical Liturgical Centre, Melbourne 1962-1989

Robert Gribben



Robert Gribben retired as Professor of Worship and Mission of the Uniting Church Faculty of Theology (part of the United Faculty of Theology) at Parkville, Victoria, in 2009. He is an Honorary Research Fellow of the MCD University of Divinity, and a Professorial Fellow of Charles Sturt University. From 1976 to 1980 he was Hon. Director of the Ecumenical Liturgical Centre in Melbourne, succeeding Dr Harold Leatherland, its founder; in later years he served in a number of capacities. This Centre was a ground-breaking ecumenical society for liturgical studies and teaching for twenty years before the founding of the Australian Academy of Liturgy.

In March 1962, the first issue of the journal *Studia Liturgica* appeared, for 'liturgical research and renewal', and a study group formed around it, involving a number of scholarly clergy in Melbourne.¹³⁴ The Rev. Dr Harold Leatherland, then a Congregationalist minister and Principal of that church's theological college in Kew, consulted the 'Heads of Churches' in Melbourne about forming a group which formally pursued the journal's aims, and in a meeting at the Independent Hall in Collins Street on 5th September, the 'Studia Liturgica Group' was established with him as its first Chairman and the Rev. Austin James, a Methodist, as secretary. All sixteen who were present, clergy and laity, became original members, and their number could be expanded by invitation or nomination – with the approval of 'the authorities of their Communion'. This was no casual enterprise. The first meeting began and ended with silent prayer; at the second they dared to try the Lord's Prayer and a Benediction. They agreed to meet three times a year.

In the first few years, the core group included the Rev. Dr Barry Marshall, the newly arrived Chaplain of Trinity College, University of Melbourne, and two Roman Catholics, Frs Greg Manly CP and Austin Cooper OMI. Their conversations focussed on the new issues arising from the journal and from the Second Vatican Council, then in session, in particular the 'Eucharist, Baptism, Holy Unction, the implementation

¹³⁴ Dr Leatherland gives an account of the development of the Centre in 'The Studia Liturgica Group, Record and Reminiscence' in the *Newsletter* of the Ecumenical Liturgical Centre, No. 10, November 1974, on which I draw here. He was on the Advisory Board and a correspondent of the new journal. There were two Australian members of Societas Liturgica at the time: Dr Leatherland and Archbishop Guilford Young in Hobart. In 1980 the present writer became the third.

of Vatican II's Constitution on the Liturgy, the Service of the Word, Prayer – its forms and language, intercession, the relation of liturgy to private prayer, consideration of revised rites in the several Communion, and the Burial rite, as these became available'.¹³⁵ They began to compile a register 'in which should be noted outstanding examples of modern ecclesiastical art and architecture in and around Melbourne, properly indexed and cross-indexed under categories, designers, craftsmen etc.'¹³⁶ This interest was a hallmark of later work in the Centre.

In 1967, the Group offered a Council of Adult Education (CAE) course of 12 lectures on Liturgy, which attracted a large enrolment; this involvement lasted a number of years and produced many of the early membership. By the end of 1968, the idea of a Liturgical Centre began to emerge, which would promote on a wider scale courses and seminars akin to ecumenical liturgical institutes in other parts of the world.

On 21st August, 1969, the group became foundation members of the 'Liturgical Centre of Victoria', established, according to its constitution, 'for the historical and pastoral study of Christian worship', with Harold Leatherland as its first Hon. Director.¹³⁷ In the first decade, those who held the Chair were Fr Bernard O'Connor,¹³⁸ Bishop Felix Arnott, the Rev. Godfrey Kircher, the Rev. Dr John Roodenburg, and Fr Gregory Manly. In this early period, the individual subscribers numbered thirty, and there were also corporate members – religious and parish congregations, liturgical committees and so on. In 1974, it changed its name to the 'Ecumenical Liturgical Centre' (ELC), and flourished until the foundation of the Australian Academy of Liturgy (AAL). In 1988, members of the ELC became members of AAL. This article attempts to put on record an account of the life of this pioneer body.

Harold Leatherland, the founder

Harold Fulton Leatherland was clearly the moving force behind the ELC. Born in England in 1909, he was ordained into the Congregational ministry there in 1933. In 1940 he married Phoebe, a *tour de force* in herself, and they had two children. Leatherland spent twelve years in Leeds (during which he gained his doctorate) and in 1956 the family emigrated first to Sydney where he became Principal and Professor of Church History at Camden (Congregational theological) College. In 1960, he moved to Melbourne, first as pastor of College Church, Parkville, the university congregation of the Presbyterian Church opposite Ormond College, and then in 1962 as Principal of the Melbourne Congregational theological college, from which he retired in

¹³⁵ Ibid. (second page, no page numbers)

¹³⁶ Ibid, third page.

¹³⁷ The last meetings of the Studia Liturgica group were held in 1970.

¹³⁸ O'Connor was parish priest of St Cecilia's RC church, South Camberwell since its establishment in 1946. He retired in 1971. He was the first President of the ELC Council. A brief obituary was published in the ELC Newsletter of December 1979 (final page).

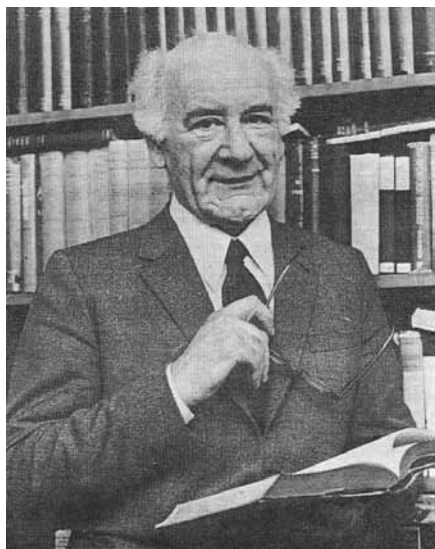

1976.¹³⁹ The *Studia Liturgica* group began to meet soon after he took up his new duties as Principal, first at Trinity College with Harold in the chair and Austin James as secretary. Later, the group met at the Leatherlands' home above Seward House in Kew, which had a simple chapel, the nearby facilities of the Congregational (later Uniting) College, and gave access to Phoebe's hospitality.

Apart from the continuing informal meetings of the liturgical group, Harold began to teach courses for credit in church history, liturgy and later in spirituality. He regularly offered two units in alternate years: the History of Christian Worship, and the Nature and Expression of Worship,

which he designed. A member of the Melbourne College of Divinity, he was the architect of the Diploma in Liturgical Studies, which provided the first steps in serious study of worship for many later leaders in the field. He held many 'schools of worship' in parishes around Victoria and beyond; he taught segments of similar courses in Catholic Theological College and at the (Catholic) National Pastoral Institute. The Ecumenical Commissions of the Catholic and Anglican Churches recognized his work, and one of his memorials is a eucharistic prayer for which he prepared the primary draft, and which appears in both Anglican and Uniting books of worship today, thus opening a unique ecumenical possibility of two churches, not yet in full communion with each other, sharing the text of such a central prayer.¹⁴⁰

He also made an early and important contribution to Christian understanding of Judaism, not merely in relation to early Christianity, but to the whole conception of worship now: the Service of the Word, the place of Scripture and psalmody, the public prayer and the blessings, the calendar of feasts and fasts, the use of sign and symbol, the great words of our liturgical language – Amen, Hallelujah, Hosanna, Maranatha – and the family nature of the Jewish religion. When I began to teach with him, I listed my lectures as 'The Jewish Background'; he more perceptively had called his 'The Gifts

¹³⁹ He brought the Congregational College into the newly formed United Faculty of Theology in Parkville in 1969, and was its President from 1973 to his retirement.

¹⁴⁰ First, in *An Australian Prayer Book* (1978) in 'The Holy Communion, Alternative Forms, Second Order, Second Form, 159-161; the Uniting Church then adopted it first in Holy Communion (1980 – known as the 'little blue booklet'), then as Alternative Great Prayer of Thanksgiving A in *Uniting in Worship*, (Leader's Book) Melbourne 1988, 104-106. It was revised for *A Prayer Book for Australia* 1995 as Thanksgiving 4, 136-138) and subsequently in *Uniting in Worship 2* (2005) in the anthology of Great Prayers of Thanksgiving at 313-315.

of the Parent Faith'. His familiarity with Judaism, in fine detail, and with synagogue worship, went back to personal friendships with rabbis in Leeds.¹⁴¹

The work of the ELC will be described further below, but first Dr Leatherland needs to be located within his own tradition. At the point of union of the Uniting Church in 1977, he was somewhat pessimistic (and he died a mere two months after its achievement). He thought that Congregationalism – the great English tradition of Independency – had had its day; and that union was inevitable. He much admired the first Basis of Union (1963) with its proposal of a church with 'bishops-in-presbytery', and a concordat with the Church of South India; he could never have conceived of the union as a pan-Protestant affair. But he knew the rock from which he was hewn: the Free Churches gave him the freedom to be the ecumenical person he was. Those who know the Puritan tradition, of which he was a distinguished exponent, knew that he was every inch (every considerable inch: he was a big man) a Congregationalist in the tradition of Isaac Watts, Owen, Perkins and Richard Baxter. He loved them for their pastoral theology, their stand for conscience against an oppressive Church and State (he himself had to leave his London parish during the Second World War because he was a pacifist), their profound Biblicism and their splendid prose. There were times when his lectures were a little too challenging for the student who, unlike Harold, did not enjoy rolling around his tongue a choice piece of 17th century grandiloquence, like a good vintage wine.

Harold was the towering figure who lay behind almost every significant moment of the Ecumenical Liturgical Centre. But there were others, who must be mentioned more briefly.

Austin James

Second in the pantheon of the ELC was the Rev. Austin James. He was born in Bendigo in 1900 and died in Melbourne in 1968. He took an MA at Melbourne University as a resident at Queen's College, and after a break during which he did farm work away from city and university influences, he offered as a candidate for the ministry. The Conference sent this learned young man to Lake Boga as a probationer, but soon after marriage and ordination, he set off to India. He served the Methodist Missions from 1925 to 1958 at Lucknow and in the Varanasi District. He became a fluent Urdu speaker and gained a profound knowledge of both Muslim and Hindu life and thought. He became a presbyter of the newly united Church of North India and a deeply committed ecumenist. Most importantly, he had imbibed the prayerful spirit of India, and it was palpable. I can still see him kneeling at the Lord's Table (the

¹⁴¹ The Centre of Jewish-Christian Dialogue, represented by Sr Leonore Sharry NDS, was a corporate member of the Centre from 1970. *ELC Newsletter*, June 1970.

'altar-table' as he preferred to call it) at South Essendon Methodist Church (originally a Primitive Methodist chapel), with the 1936 *Book of Offices* lying open before him unread, reciting the Communion Prayer by heart, eyes fixed on heaven, communing with God in the Spirit.¹⁴²

After his death, the Centre created a public lecture in his honour. In 1972 Harold Leatherland gave the inaugural one: 'Liturgy – How does Trad become Mod?', and a lecture was sponsored annually, with few breaks until the Centre closed in 1989. Apart from the full spectrum of Australian scholars, international luminaries included David Frost, Gerard Austin OP, David Power OMI, Louis Weil and Geoffrey Wainwright. Under the auspices of the Academy, the Methodists Geoffrey Wainwright and Karen Westerfield Tucker and the Anglican David Holton have given this lecture. Almost all were published either singly or within the ELC's newsletter. The lectures continue occasionally under the AAL (Victorian Chapter).

Barry Marshall and Greg Manly



The well-beloved chaplain at Trinity College, Dr Barry Marshall OGS (1923-1970), also has a eponymous memorial lecture, sponsored annually by that College. Raised in rural New South Wales, he graduated in Arts in Melbourne and read theology at Morpeth, taking Firsts in both, and was ordained in 1950 as Brother Timothy of the Brotherhood of the Good Shepherd, otherwise known as the Bush Brothers. After serving in the outback, in 1952, he went to Oxford, completed a D. Phil. in 1955, and returned to work in Bourke. The role of bush pastor never left him, though he was a sophisticated scholar and a delightful companion. Later, he spent some time at the Institut Catholique

in Paris, absorbing the vision of liturgical renewal in the Roman Church, which he brought to his ministry at Trinity College from 1961. He had a particular interest in Christian initiation, and it is apt that, following death by accident in 1970, his ashes are buried by the font in Trinity Chapel.

¹⁴² I owe some of the biographical details to an earlier account by James's friend and colleague in India, the Rev. Stan Weeks, published in ELC Newsletter 82/2, and to the Rev. Colin Honey. Austin James was also a notable leader of silent retreats.

Father Gregory Manly CP (1920-2012) was born in Dublin, professed in the Passionist Congregation in 1943 and ordained in 1950. He arrived in Melbourne (Holy Cross seminary) in 1964, just as the impact of Vatican II began to be felt.¹⁴³ He was immediately part of the Studia Liturgica group and what grew from it. He appears as a regular lecturer from the first Newsletter (June 1970) where he is also named as a member of the Council, representing the Passionist Community which was a 'corporate member'. A year later he reports on his tour of Europe and the USA, including his conversations with Père Gelineau and other liturgical stars of the era. I remember attending his lectures on church architecture, and on the liturgy of the 'new' eucharist, with the emphasis on creating community and prayer, themes which he developed in later talks. His book *At the Table of the Lord* (Spectrum, 1973) is reviewed in the Newsletter for that year. He was later President of the Centre's Council. Most notably, he worked closely with Sr Anneliese Reinhard, a Missionary Sister of the Sacred Heart, who had come from her native Germany in 1958, bringing her experience in novice formation, pastoral counselling and spiritual direction. Fr Tom McDonough has said that Sr Anneliese 'brought him [Greg] out of his head and introduced him to his heart', and the heart was what he then brought to his liturgical formation. I had the privilege in 1984 of launching their book *The Art of Praying Liturgy* (Melbourne: Spectrum). It is a deeply personal book, and opens the hearts of readers to the centre of the eucharistic liturgy and the eucharistic experience. The book needs urgent re-reading in the light of the present mood in Rome.

Greg delivered the Austin James Lecture on two occasions. The first, in 1977, was entitled 'Liturgical Formation – a praying need'. He proposed moving beyond the study of the liturgy (historically, comparatively, theologically) to the formation of the people of God *in* the liturgy, and he describes the method on which he and Sr Anneliese and others had been working in the previous four or five years. He acknowledges that *talking* about the method is very much a second-best. Looking at the liturgical changes in the period following Vatican 2, he asks whether there has been concomitant deepening of people's prayer – for surely 'liturgy is *people praying?*' Liturgy is not 'the choir singing, nor the preacher preaching, not the minister leading'. The Constitution on the Liturgy of the Vatican Council was stressing *participation*, which was not just keeping the people busy! The praying community needs to be *receptive* (not active, not passive) in the liturgy in order that their prayer arises from the centre of their being. They need to *respond* to what is going on. Then they 'externalize' this in symbolic activity, fundamentally in eating bread and drinking wine. He goes on to spell out some of the ways in which all this might happen, including the acquisition of the necessary skills *in the congregation*.

¹⁴³ This section draws on the obituary which I wrote and published in AJL 12-1, 2010.

The work of the Centre

Communication among members was through the *Newsletter* published twice a year from June 1970. Its readers that year were calculated at 54 personal members¹⁴⁴, 16 associate members¹⁴⁵ and 13 corporate members. Dr Leatherland was designated Hon. Director. A 10-week CAE course on 'The History of Christian Liturgies' had been presented in March, and was attended by 25 people. The opening lecture was given by Rabbi John S. Levi, followed by Fr John Prendiville, Rev. Alfred Bird, Fr Paul Ryan, Fr Greg Manly, Fr Oliver O'Brien and architect David Pincus. The participants were invited at the end to the convent of the Sisters of the Blessed Sacrament in Armidale to see the production of altar-breads and to join in the Community's prayers. A second course in July was on 'The Building for Christian Worship today'.

By September 1971, two Patrons had been appointed, the Catholic Archbishop of Melbourne, Dr J. R. Knox, and the Anglican Archbishop, Dr Frank Woods. During this early period of the Centre, there was discussion about forming or joining groups on the liturgical arts and liturgical dance.¹⁴⁶ Liturgical travellers like Harold Leatherland and Greg Manly gave reports on their experiences. The Diploma in Liturgical Studies was announced. A seminar was offered to 'people involved in Christian Education', a course for lay people on 'How to Worship' (predictably led by Greg Manly), a course on 'contemporary Celebration: Principles and Guidelines' and finally a seminar on 'Using the Imagination' which would be quite enough for a year, except that CAE classes were maintained alongside the Centre's own. This busyness is typical of the early years of the Centre's work in the astonishing variety and contemporary relevance.

In March 1972, 97 personal members are claimed, 25 associate and 16 corporate, but the note is added 'the Centre is represented in every State within Australia, and in London, South India and Manila.'¹⁴⁷ The implications of this are noted: 'Is it feasible to think of an Australian Liturgical Society, with an office in this ecumenical liturgical centre in Melbourne? We have Associate Members in each of the Australian States; there are interesting and important liturgical activities in many places; helpful and informative periodicals are published in several cities. But many of us are still working in isolation and probably none are aware of what is happening throughout Australia' – and Dr Leatherland (as editor) goes on to raise a number of possible contributions which might be made. This vision lasted as long as the Centre did.

¹⁴⁴ My name is listed from September 1970. I began to give lectures in 1975 on return to Melbourne from my first circuit in Portland, Vic.

¹⁴⁵ Associate members were corporate bodies such as libraries and religious congregations, or were persons who lived beyond Melbourne.

¹⁴⁶ The Liturgical Dance Group was formed in 1971 with support from the Centre. Its great moment came with the 1980 World Council of Churches conference on Mission and Evangelism when they prepared and performed the dances for an ecumenical service at St Patrick's Cathedral on Ascension Day. See ELC Newsletter 80/3. Among its leaders were Felicity Fallon and Nell Challingsworth.

¹⁴⁷ ELC Newsletter No. 5, March 1972, first page.

Harold Leatherland retired as Hon. Director at the end of 1976, and was appointed a Patron soon thereafter alongside Archbishop Woods, Cardinal James Knox (then Prefect of the Sacred Congregation for the Sacraments and Divine Worship) and the Catholic Archbishop of Melbourne, Frank Little. The present writer succeeded Dr Leatherland as Hon. Director. I was then Chaplain of Ormond College at the University of Melbourne, and W.A. Sanderson Fellow in Liturgical Studies, a new position from 1979, teaching at the United Faculty of Theology. In my five years, the programme continued along its usual lines with a variety of seminars and lecture courses. The advent of the Uniting Church added zest to the ecumenical discussion of new liturgical forms. The ecumenical breadth increased to include lectures by Pastor Vernon Kleinig (Lutheran) and the Rev. Bill Tabbernee (Church of Christ).

The Leatherland Exhibition

The death of the founder on 29th August 1977 inspired the H. F. Leatherland Fund¹⁴⁸ to honour his name, with the purposes of offering an Exhibition for an essay in the liturgical field by a student in the MCD Dip. Lit. Studs or for the B. Theol. (it was later opened to any Australian student of liturgy enrolled in a recognized institution), grants to assist research, including travel, and library grants first to the library of the Centre itself, and then to what is now the Dalton McCaughey Library at the Centre for Theology and Ministry in Parkville, where Dr Leatherland's own library had been placed and separately catalogued.

The first recipient of the Exhibition, in 1981, was Fr Shane O'Connor O. Carm., for an essay entitled 'The origin and development of the Carmelite rite up to its suppression after Vatican II', and it was awarded at the MCD graduation in April.¹⁴⁹ Not all who submitted an essay were judged to have reached the required standard, so it was somewhat rarely awarded. Under the Academy, two memorable winners were the Rev. Ian Ferguson (Uniting Church) on 'Remembering the Body: Human embodiment and liturgical practice' (1997), and Mr Stuart Hibbert (Anglican) for a meticulous preparation of the liturgy of the Syrian Orthodox liturgy in English for the guidance of its congregations in Melbourne (2007).

¹⁴⁸ The ELC Newsletter of May 1979 published the sermon Dr Leatherland delivered at College Church, Parkville, on the Sunday before he died, and formally launched the Fund. The amount raised and invested was \$4418.00. The Exhibition was initially of \$100; most recently, of \$500. The Fund has been administered by a Trust with members representing the Melbourne College of Divinity (latterly the MCD University of Divinity) and the Victorian Chapter of the Academy. The terms of the Fund have been modified by the Trust over the years; e.g. the low income meant that travel grants soon ceased. The book and journal grants to the library have been a constant.

¹⁴⁹ ELC Newsletter 82/1

Australian Ecumenical Liturgical projects

In significant ways the Ecumenical Liturgical Centre provided the ground – and the personnel – for the Australian Consultation on English Texts from October 1976¹⁵⁰ and its successor, the Australian Consultation on Liturgy (ACOL).¹⁵¹

The first ELC Newsletter in 1970 had reported on an early connection with the Melbourne ad hoc committee for the study of liturgical texts under the Rev. Dr Percy Jones. Dr Jones was a member of the ecumenical International Consultation on English Texts (ICET) which had published *Prayers We Have in Common*¹⁵² which included two sets of texts with commentary. These were revised in the light of criticism and published under the same title in 1975¹⁵³ before ICET went out of existence. The decade of the 1970s was busy liturgically for several Australian churches. In 1976, the Anglican Liturgical Commission invited some ecumenical members to join them ‘in a personal capacity’ as they prepared *An Australian Prayer Book* (1978). Soon afterwards, a new, national, body was formed by formal appointment by the participating churches, which became the Australian Consultation on Liturgy (ACOL). It became affiliated with the international ecumenical body which had then formed, the English Language Liturgical Consultation (ELLC), and sent regular delegates to ELLC’s meetings.¹⁵⁴ ACOL’s first secretaries were Hon. Directors of the ELC, and its current work is now regularly reported in this *Australian Journal of Liturgy*.

Another offshoot – briefly – named itself the Collins’ Joint Lectionary Project, a project of Collins Publishers (London) under the direction of Suzanne and Geoffrey Chapman. It arose from the involvement of Collins in the publication of the *Australian Hymn Book* and Geoffrey Chapman’s knowledge of the ecumenical work on *An Australian Prayer Book*. He proposed¹⁵⁵ the publication of a lectionary – in the sense of a book with the lections set out in a common translation for reading in the liturgy – which would indicate the variations in the use of the *Revised Common Lectionary* which several Australian churches were already using. One task was to

¹⁵⁰ From ‘Notes from a Consultation on Common Forms in Worship’, its first meeting. Present were Canon L. F. Bartlett (‘C of E’), Rev. Dr G. H. Blackburn (Baptist), Dr Evan Burge (Ang.), Rev. Robert Gribben (Methodist – mistakenly listed as ‘Congregational!’), Rev. Dr Athol Gill (Baptist), Bishop John Grindrod (Ang.), Rev. Prof. J. D. McCaughey (Presbyterian), Revs. H. Proeve and E. Wiebusch (Lutheran), Rev. D’Arcy Wood (Meth.), and Archbishop Guilford Young (R.C.). In 1978, there was Greek Orthodox and Presbyterian (sc. post Uniting) membership also; a Churches of Christ representative joined in 1980. At its second meeting under that name (July 1977) my secretarial skills were further called upon. By June 1978, it had become ACOL.

¹⁵¹ There was a slight controversy in the pages of Melbourne’s newspaper *The Age* after the Religious Affairs writer, Mark Baker, announced that the Lord’s Prayer was to be ‘rewritten’. Dr David McCaughey had to write a calming response. *The Age*, 5/10/76, 7/10/76.

¹⁵² Subtitled ‘Agreed Liturgical texts proposed by ICET’, Geoffrey Chapman, 1970. A copy of these Notes are in my possession.

¹⁵³ SPCK 1975.

¹⁵⁴ The Rev. Dr D’Arcy Wood wrote a chapter on the history and work of ACOL in *Apples of Gold: essays in honour of H. P. V. Renner on the occasion of his retirement*, ed. Inari Thiel, Brisbane: The Sophia Collective, 1992, 108-114.

¹⁵⁵ In a letter to Dr Evan Burge, then Warden of Trinity College, on 19th May 1978.

convince all to use a version of the three-year *Revised Standard Version* of the Bible, for which Geoffrey Chapman Ltd held a right to publish, and the psalter as translated by Professor David Frost. By 1978, ACET had become ACOL and my role as ACOL secretary (and Hon. Director of the ELC) was formalised as Executive Secretary of the project and Evan Burge as its chairman.¹⁵⁶ Fr Gilbert Sinden SSM was engaged as Editor. Expenses were paid for by Collins. There was interest also from New Zealand in the lectionary project. As time went on and negotiations continued, a smaller executive was appointed to meet in Melbourne. Huge amounts of detailed text were sent back and forth – but during 1980 the project was abandoned. In the meantime, a group of liturgical scholars had learned a great deal, and forged some very close friendships.

Leadership and programme

Late in 1980, I accepted the role of Ecumenical Lecturer at the Church of England's theological college in Lincoln, U.K. and Father Patrick Bishop S.J. became Hon. Director of the ELC. He and I had jointly taught liturgical courses at the United Faculty of Theology. Bishop James Grant became Chairman of the ELC Council, and Fr Peter Cross gave the Austin James Lecture on 'The Revised Rites of Christian Initiation of Adults', to which Fr Ron Dowling (Ang.), Rev. Bruce Barber (Uniting) and Fr Peter Conroy (RC) responded. The catechumenate was becoming a common term in liturgical parlance well beyond the Roman Catholic Church. The ELC Newsletter continued to publish articles on liturgical subjects, to review books and to announce courses. In 1981, the Rev. Ron Dowling (Anglican, then Vicar of St Margaret's, Eltham) became Hon. Director. Each change of director necessitated the moving of a large number of books in the Centre's Library across Melbourne!¹⁵⁷ Frances Gillard took on the editorship of the Newsletter. Being now placed in the UK, I was able to attend a congress of the Societas Liturgica in Paris – where I encountered the important exploration of liturgical time by Dr Thomas Talley – and wrote a report for the Newsletter (82/2). Ron Dowling was appointed for a second three-year term, and when I returned in 1984, I replaced Bishop Grant as Chairman of the ELC Council. The Rev. David Brown became its secretary, soon to be followed by the Rev. Graham Gall (both Uniting). In 1986, Fr Harry Aveling (Liberal Catholic Church) became Editor of the Newsletter. This year marked the death of Fr Anthony Cleary, an early member and strong supporter of the Centre, who had pioneered post-Vatican II architecture in his new parish church, Holy Name, East Preston.¹⁵⁸

¹⁵⁶ The project members were Revs. Dr Evan Burge, Canon Lawrence Bartlett and Anthony Taylor (Anglican), Bishop Edward Clancy, Fr Denis Hart and Very Rev. Dr Percy Jones (RC), Revs. H.F.W. Proeve, V.C. Pfitzner and H.P.V. Renner (Lutheran), Revs. Robert Gribben, Dr Gordon Dicker and Dennis Towner (Uniting)

¹⁵⁷ It was moved to the 'Joint Theological Library' at Ormond College in 1989.

¹⁵⁸ Sr Marg Smith sgs recalls his contribution and this building (see photos there) in her article '*Sacrosanctum Concilium*: The Australian way, part 1', *AJL*, 13/2, 2012, 53-54.

Joining with the Academy

The ELC leadership watched the formation of the Australian Academy of Liturgy (AAL) with interest. Ron Dowling and some other ELC members had attended the first meeting in Adelaide at the end of November 1982, but it would appear that the existence of the ELC was not known among the founding members. The examples of international liturgical associations and graduate liturgical study possibilities, especially in the post-Vatican II Catholic universities and seminaries were a vivid reality for many there. During 1988, the ELC Council began to consider the future of the Centre, and on 30 August, it met with the executive of the AAL's Victorian Chapter. In 1987 there were 94 members of the Centre, across Australia (and a call to pay up subscriptions). It was agreed that ELC members would be welcome as members and associates of the AAL, and arrangements were put in place for the administration of the Leatherland Fund and the Austin James Lecture. The AGM of 30th September 1988 made the decision to dissolve the Ecumenical Liturgical Centre. The Epiphany 1989 Newsletter is full of historic record with a touch of nostalgia, but also with a recognition that it was right that we should go out of existence in favour of the new body.

I acknowledge that this is a somewhat personal essay, and a certain sadness remains with me. The transition did not work well for the Centre. The intention to be an *academy*, with relevant standards of presentation and of membership, dissuaded many active lay members (in particular) from continuing to attend activities. The activities on the CAE model had ceased. The strong non-Roman Catholic leadership of the Centre was always somewhat tenuous since opportunities for Anglican and Protestant scholars to pursue liturgical studies were much rarer and less well funded than those for Catholics. However, there is a tale told here of transforming teaching and example, of the opening of a world of worship I had only dreamed of as a young Methodist, of the discovery of the rich variety by which Christians glorify their Trinitarian God, and above all, the experience of what might be called ecumenical *agape*, ecumenical friendships, which have sustained me for a lifetime. For all this, many across Australia join with me in giving thanks to God.



FROM THE PRESIDENT

Angela McCarthy

In our 2009 *Australian Journal of Liturgy* (volume 11/3), our previous president Dr David Pitman, first talked about the coming milestone of the 30th anniversary of the first meeting of what was to become the Australian Academy of Liturgy. That milestone in fact passed in December 2012, so this year we are celebrating the 30th anniversary of the first AAL conference. The conference, celebrating renewal – ‘Liturgical Renewal: Sound, Space, Presence’, was held in Hobart, and proved to be interesting and fruitful. It brought to mind a number of times within the conference the purpose of our existence.

- To provide channels for mutual professional assistance and for the sharing of methods and resources
- To exchange information concerning recent developments in liturgical matters
- To communicate information concerning research projects and activities of its members
- To foster liturgical research, publication, and dialogue at a scholarly level
- To publish the *Australian Journal of Liturgy*
- To encourage exchanges with individuals and communities of other religious traditions

To my mind, the purpose for which we exist is entirely evident through what we heard and discussed at the conference and through our journal which is so ably edited by Robert Gribben. This current issue holds the key note addresses of Stephen Hackett, Peter Williams and Colleen O’Reilly as well as the public lecture once again given by Clare V. Johnson.

Stephen Hackett shared some of his PhD material about the changes made to liturgical space, not just post Vatican II, but beginning with the ‘Liturgical Movement’. Fan shaped worship spaces with sloping floors expressed a renewed liturgical theology.



Photo courtesy of Julie Moran

Dr Angela McCarthy, AAL President speaks with Dr Russell Hardiman (W.A. Chapter).

Peter Williams spoke about sound but not just the sound of music, the other sounds too that have altered in the renewal of our worship practice.

Colleen O'Reilly brought a particularly feminine understanding of presiding in worship and of course spoke about the difficulties and joys of the journey towards the acceptance of the ordination of women. Unfortunately Margaret Smith was not able to join in conversation with Colleen, as advertised, due to some health challenges.

We were also privileged to have Michael Hawn with us, an internationally renowned musician and teacher who viewed the renewal of liturgical music through various Christian denominations. The other short papers moved around many different areas of renewal and offered great opportunities for discussions between the different traditions.

Our conference dinner gave us an opportunity to hear the history of the AAL from the perspective of Anthony Kain who convened the first meeting. This journal also offers a further perspective from our editor, Robert Gribben.

Particular thanks go to the Tasmanian Chapter for their wonderful hospitality, ably lead by Alison Whish. Many thanks to you all for your support of the conference and wonderful organisation of liturgies and conference needs.

The General Meeting decided that the next conference would be in Brisbane and planning is under way from our Queensland Chapter. The WA Chapter will continue with the Executive until the Brisbane conference. Currently all records are being transferred to a single data base management system which will ease our membership and financial record keeping practice.

On a sadder note, Kevin Seasoltz OSB died on April 27. His book *A Sense of the Sacred* would have been well known to many of you and some of you would have met him on his Australian visit some years ago. His meeting with the WA Chapter was very memorable for his warm eloquence and scholarship.

Thank you to all members for your contributions to the Academy and we look forward to an enthusiastic conference in Brisbane.

STATE CHAPTER REPORTS

New South Wales – Monica Barlow

The NSW Chapter continues to meet every second month. Our initial meeting for the year focussed on sharing the fruits of the Hobart Conference with those unable to be there. It was a good way of distilling what had stayed with us. We look forward to further exploring some of the themes as the year progresses. We continue to try to enlarge our membership with those from other denominations – we are too Roman Catholic!

Queensland – Inari Thiel

The Queensland chapter met at St Francis' Theological College in early February, when members shared their experience of the Hobart conference, and exchanged news from the various denominations.

For our April meeting, we travelled to Stella Maris Parish in Maroochydore, where members from the Sunshine Coast and Maryborough joined those from Brisbane and surrounds to enjoy lunch and discuss ideas for our hosting of the 2015 conference.

The next meeting will be back at St Francis Theological College in Milton on Tuesday, 4th June; and for our August meeting we hope to travel to Toowoomba, in order to share with members from the Darling Downs area.

South Australia – Ilsa Neicinieks.

Our Chapter had its first meeting for 2013 in March. Given that three of our members were overseas at the time of the January Conference in Hobart and Anthony Kain was the only South Australian representative, the bulk of the meeting was spent hearing Anthony's interesting and comprehensive report on the AAL Conference.

We had also intended to spend some time discussing an article in the last issue of the AAL Journal but time escaped us and so this has been postponed until May.

Tasmania - Alison Whish

The Tasmanian chapter was delighted to welcome a good number of members to Hobart for the recent conference In January. We enjoyed providing glimpses of our beautiful home and sharing in some stimulating papers. Having waved you all goodbye, the Chapter has slumped into somewhat of a post conference lull and a time of attending to other things.

However, the pressing question of how we evolve new ways of worshipping that links us with our tradition but takes our communities forward into the future, is a significant and largely present question for some of us. What are the authentic forms of worship for communities of six to fifteen? How do the people share the sacraments when there are no ordained ministers available? What forms of worship can emerge with integrity when Christians are scattered and striving to embody their faith in the community in which they live and work. And in our Tasmanian context, all this with a legacy of buildings that served the church well in the 19th century and now do not.

Victoria – Tony Doran and D’Arcy Wood

In 2012 we met bi-monthly at St Francis’ Pastoral Centre in the Melbourne CBD and will continue to do so in 2013. The hospitality of the team there is greatly appreciated. In the past year we enjoyed papers by Tom Knowles, Charles Sherlock and Robert Gribben. Copies (or summaries) of these are available to AAL members if requested. We also discussed a book on ‘Pentecostal Sacraments’ by the American scholar Daniel Tomberlin.

We began 2013 with a planning meeting at which we also reviewed the National Conference in Hobart. A good contingent of Victorians attended and they assessed the conference as highly successful.

On 8th May Robert Gribben will give an account of two auspicious liturgical events of 2012, the enthronement of the new Archbishop of Canterbury and the inauguration of His Holiness Pope Francis. On 10th July Garry Deverell will give a paper entitled ‘Factors contributing to the failure of liturgical reform in the Uniting Church’. The following meeting will be on 11th September when Emily Fraser will report on her work on the content and context of hymn texts by Martin Luther, Charles Wesley and Elizabeth Smith. Emily is an Anglican deacon and a PhD candidate. In late October we plan to tour churches in the town of Castlemaine and share a barbecue hosted by our co-convener Tony Doran, the Catholic Parish Priest.

Our membership list in Victoria is far greater than our attendance at meetings, the latter varying from 5 to 11. Visitors to Victoria, AAL members or otherwise, are always welcome at our meetings. Contact D’Arcy Wood on 03-5428-3040 or Tony Doran on 03-5472-1900.

Western Australia – Angela McCarthy (for Viv Larkin)

The WA Chapter has met twice in 2013 and on both occasions has had the pleasure of the company of Fr Tom Scirghi SJ. Fr Tom is a sacramental and liturgical theologian who teaches at Fordham University in New York. He unfortunately missed our Hobart

conference because he had already come over to WA to take up the Chair of Jesuit Studies at St Thomas More College, UWA. His additional wisdom and good humour have been a great addition to our meetings. We have also welcomed a new guest, Mary Ann Lumley who is a teacher and responsible for liturgy at a large Catholic School. Our focus has been the book *The Worshipping Body: The Art of Leading Worship* by Kimberly Bracken Long. Fr Tom commented that he wished he had the book earlier in order to speak to his class about the use of the body when presiding at liturgy. We will continue working through the book this year and conclude with our weekend at New Norcia Monastery in December.

Book reviews note

AJL seeks to provide book reviews of texts related to liturgical renewal and liturgical studies, especially but not only those in some way related to Australian environments and/or by Australian authors. The reviews section is open to studies of/in both mainstream and minority traditions, with either textual or contextual foci, theological or historical bent, and welcomes reviews of possible core texts and course texts for academic study as well as books making practice-focused proposals, presiding manuals and materials for assembly formation. Reviews are usually circa 800 words and tend to include summary, points of note, question and contest.

AJL seeks book reviewers. To suggest a book for review, please email sburns@eds.edu To offer to join a pool of regular reviewers, please email sburns@eds.edu To volunteer a particular review, please email sburns@eds.edu (The book reviews editor will endeavor to have the publisher send a review copy to the reviewer.) To enquire about the small number of books which are seeking a reviewer, please email sburns@eds.edu Thank you.

Forthcoming reviews:

Anne Elvey, Carol Hogan, Kim Power and Clare Rankin, eds, *Reinterpreting the Eucharist: Explorations in Feminist Theology and Ethics*. Sheffield, Equinox, 2012. (Stephen Burns)

Louis Weil, *Liturgical Sense*. New York, NY: Church Publishing, 2013. (Stephen Burns)

Editor's note: In fact the wealth of material for AJL following our Hobart Conference is such that I am happy to hold over book reviews for this issue. RWG.

AJL addresses

Manuscripts for publication to: The Editor, AJL
22 Illawarra Road,
Balwyn North, Victoria 3104
Phone: (03) 9859 1750
Email: rgribben@ozemail.com.au

Authors preparing manuscripts are requested to follow the Turabian style (a variation on the Chicago style) for footnotes and any bibliography. The Harvard or author-date system is not used. For most cases, the 'quick guide' to the manual, http://www.press.uchicago.edu/books/turabian/turabian_citationguide.html will be found to be sufficient. Texts which insufficiently adhere to these may be returned for correction.

Articles should not normally exceed 5,000 words in length. Articles may be submitted initially by an attachment to an email or a disc. **Photographs** need to be of sufficient definition to print in black and white, though colour may be submitted, preferably on disc.

Only articles not previously published and not under consideration for publication elsewhere will be accepted. All articles submitted will be reviewed by the *AJL* editorial panel or other reviewers with appropriate expertise. The *Australian Journal of Liturgy* is listed in the Register of Refereed Journals published by the Department of Education, Science and Training (DEST), Canberra. Copyright © Australian Academy of Liturgy ISSN 1030-617X

The *Australian Journal of Liturgy* should be abbreviated as *AJL*.

Books for review to: Episcopal Divinity School
99 Brattle Street
Cambridge, MA 20138, USA
Email: sburns@eds.edu

Subscription payments to: The Secretary
Australian Academy of Liturgy
(and all other business communications) 22 Maritime Avenue
(including notice of change of address) Kardinya, WA, 6163
Email: angela.mccarthy@nd.edu.au

The annual fee for a single member is \$37 (GST incl.); for a single retired person, \$15 and for a retired couple, \$25, for other couples, \$42. These fees include a subscription to *AJL*. For *AJL* alone, it may be sent anywhere in the world for AU\$25 if paid in Australian currency, and the equivalent of AU\$30 if paid in any other currency.

Advertising is accepted: \$20 per half page.

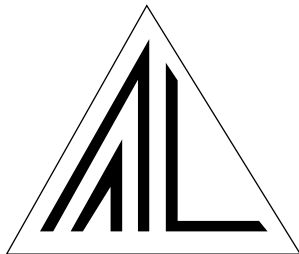

AUSTRALIAN ACADEMY OF LITURGY